

OPERATION MANUAL



MAYCO SERIES MODEL LS600P CONCRETE PUMP (Perkins 1104D-44TA DIESEL ENGINE)

Revision #0 (05/13/13)

To find the latest revision of this
publication, visit our website at:
www.multiquip.com



THIS MANUAL MUST ACCOMPANY THE EQUIPMENT AT ALL TIMES.



WARNING

CALIFORNIA — Proposition 65 Warning

Diesel engine exhaust and some of its constituents are known to the State of California to cause cancer, birth defects and other reproductive harm.

Dust created by power sanding, sawing, grinding, drilling and other construction activities also contain chemicals known to cause cancer.

Some examples of these chemicals are:

- Lead from lead-based paints
- Crystalline silica from bricks
- Cement and other masonry products
- Arsenic and chromium from chemically treated lumber

Your risk from these exposures varies, depending on how often you do this type of work. To reduce your exposure to these chemicals: **ALWAYS** work in a well-ventilated area, and work with approved safety equipment, such as dust masks that are specially designed to filter out microscopic particles.

SILICOSIS/RESPIRATORY WARNINGS

⚠ WARNING



SILICOSIS WARNING

Grinding/cutting/drilling of masonry, concrete, metal and other materials with silica in their composition may give off dust or mists containing crystalline silica. Silica is a basic component of sand, quartz, brick clay, granite and numerous other minerals and rocks. Repeated and/or substantial inhalation of airborne crystalline silica can cause serious or fatal respiratory diseases, including silicosis. In addition, California and some other authorities have listed respirable crystalline silica as a substance known to cause cancer. When cutting such materials, always follow the respiratory precautions mentioned above.

⚠ WARNING

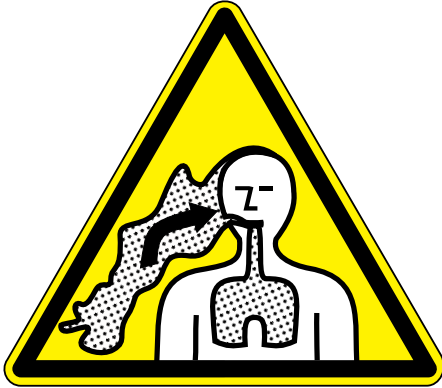

RESPIRATORY HAZARDS

Grinding/cutting/drilling of masonry, concrete, metal and other materials can generate dust, mists and fumes containing chemicals known to cause serious or fatal injury or illness, such as respiratory disease, cancer, birth defects or other reproductive harm. If you are unfamiliar with the risks associated with the particular process and/or material being cut or the composition of the tool being used, review the material safety data sheet and/or consult your employer, the material manufacturer/supplier, governmental agencies such as OSHA and NIOSH and other sources on hazardous materials. California and some other authorities, for instance, have published lists of substances known to cause cancer, reproductive toxicity, or other harmful effects.

Control dust, mist and fumes at the source where possible. In this regard use good work practices and follow the recommendations of the manufacturers or suppliers, OSHA/NIOSH, and occupational and trade associations. Water should be used for dust suppression when wet cutting is feasible. When the hazards from inhalation of dust, mists and fumes cannot be eliminated, the operator and any bystanders should always wear a respirator approved by NIOSH/MSHA for the materials being used.

TABLE OF CONTENTS

LS600P Concrete Pump

Proposition 65 Warning	2
Silicosis/Respiratory Warnings	3
Table Of Contents	4
Parts Ordering Procedures.....	5
Safety Information	6-11
Specifications	12
Dimensions.....	13
Important Hand Signals.....	14
General Information.....	15-21
Pump Components.....	22-25
Digital Control Panel Components	26-27
Engine Components	28
Inspection	29-31
Setup	32
Operation.....	33-38
Maintenance	39-51
Trailer Maintenance	52-54
Trailer Guidelines.....	55-69
Appendix — Concrete Mix Information.....	70-72
Troubleshooting (Pump)	73-74
Troubleshooting (Engine).....	75
Troubleshooting (Hydraulic Brakes).....	76
Troubleshooting (Electrical)	77
Control Box Component Locator	78
Wiring Diagram Control Box (Internal).....	79
Hopper Vibrator Locator	80
Wiring Diagram Hopper Vibrator.....	81
Hydraulic System Locator Diagram	82
Hydraulic System Diagram	83
Wiring Diagram Locator 1 (External Control Box) .	84
Wiring Diagram 1 (External Control Box)	85
Wiring Diagram Locator 2 (External Control Box) .	86
Wiring Diagram 2 (External Control Box)	87

NOTICE

Specifications are subject to change without notice.

PARTS ORDERING PROCEDURES

Ordering parts has never been easier! Choose from three easy options:

Effective:
January 1st, 2006



Order via Internet (Dealers Only):

Order parts on-line using Multiquip's SmartEquip website!

- View Parts Diagrams
- Order Parts
- Print Specification Information



If you have an MQ Account, to obtain a Username and Password, E-mail us at: parts@multiquip.com.

To obtain an MQ Account, contact your District Sales Manager for more information.

Goto www.multiquip.com and click on **Order Parts** to log in and save!

Use the **internet** and qualify for a **5% Discount** on *Standard orders* for all orders which include complete part numbers.*

Note: Discounts Are Subject To Change



Order via Fax (Dealers Only):

All customers are welcome to order parts via Fax.

Domestic (US) Customers dial:
1-800-6-PARTS-7 (800-672-7877)

Fax your order in and qualify for a **2% Discount** on *Standard orders* for all orders which include complete part numbers.*

Note: Discounts Are Subject To Change



Order via Phone: Domestic (US) Dealers Call:
1-800-427-1244

Non-Dealer Customers:

Contact your local Multiquip Dealer for parts or call 800-427-1244 for help in locating a dealer near you.



International Customers should contact their local Multiquip Representatives for Parts Ordering information.

When ordering parts, please supply:

- | | |
|---|--|
| <input type="checkbox"/> Dealer Account Number | <input type="checkbox"/> Specify Preferred Method of Shipment: |
| <input type="checkbox"/> Dealer Name and Address | <input checked="" type="checkbox"/> UPS/Fed Ex <input checked="" type="checkbox"/> DHL |
| <input type="checkbox"/> Shipping Address (if different than billing address) | <input type="checkbox"/> Priority One <input checked="" type="checkbox"/> Truck |
| <input type="checkbox"/> Return Fax Number | <input type="checkbox"/> Ground |
| <input type="checkbox"/> Applicable Model Number | <input type="checkbox"/> Next Day |
| <input type="checkbox"/> Quantity, Part Number and Description of Each Part | <input type="checkbox"/> Second/Third Day |

NOTICE

All orders are treated as *Standard Orders* and will ship the same day if received prior to 3PM PST.

WE ACCEPT ALL MAJOR CREDIT CARDS!



www.multiquip.com



SAFETY INFORMATION

Do not operate or service the equipment before reading the entire manual. Safety precautions should be followed at all times when operating this equipment. Failure to read and understand the safety messages and operating instructions could result in injury to yourself and others.



SAFETY MESSAGES

The four safety messages shown below will inform you about potential hazards that could injure you or others. The safety messages specifically address the level of exposure to the operator and are preceded by one of four words: **DANGER**, **WARNING**, **CAUTION** or **NOTICE**.

SAFETY SYMBOLS

! DANGER

Indicates a hazardous situation which, if not avoided, **WILL** result in **DEATH** or **SERIOUS INJURY**.

! WARNING

Indicates a hazardous situation which, if not avoided, **COULD** result in **DEATH** or **SERIOUS INJURY**.









! CAUTION

Indicates a hazardous situation which, if not avoided, **COULD** result in **MINOR** or **MODERATE INJURY**.

NOTICE

Addresses practices not related to personal injury.

Potential hazards associated with the operation of this equipment will be referenced with hazard symbols which may appear throughout this manual in conjunction with safety messages.

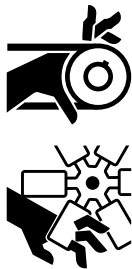
Symbol	Safety Hazard
	Lethal Exhaust Gas Hazards
	Explosive Fuel Hazards
	Burn Hazards
	Respiratory Hazards
	Eye and Hearing Hazards
	Accidental Starting Hazards
	Pressure Hazards
	Hydraulic Fluid Hazards
	Rotating Parts Hazards

SAFETY INFORMATION

GENERAL SAFETY

CAUTION

- **NEVER** operate this equipment without proper protective clothing, shatterproof glasses, respiratory protection, hearing protection, steel-toed boots and other protective devices required by the job or city and state regulations.



- **NEVER** operate this equipment when not feeling well due to fatigue, illness or when under medication.



- **NEVER** operate this equipment under the influence of drugs or alcohol.



NOTICE

- This equipment should only be operated by trained and qualified personnel 18 years of age and older.
- Whenever necessary, replace nameplate, operation and safety decals when they become difficult read.
- Manufacturer does not assume responsibility for any accident due to equipment modifications. Unauthorized equipment modification will void all warranties.
- **NEVER** use accessories or attachments that are not recommended by Multiquip for this equipment. Damage to the equipment and/or injury to user may result.
- **ALWAYS** know the location of the nearest **fire extinguisher**.
- **ALWAYS** know the location of the nearest **first aid kit**.
- **ALWAYS** know the location of the nearest phone or **keep a phone on the job site**. Also, know the phone numbers of the nearest **ambulance**, **doctor** and **fire department**. This information will be invaluable in the case of an emergency.



PUMP SAFETY

DANGER

- **NEVER** pump volatile, explosive, flammable or low flash point fluids. These fluids could ignite or explode.
- The engine fuel exhaust gases contain poisonous carbon monoxide. This gas is colorless and odorless, and can cause death if inhaled.
- The engine of this equipment requires an adequate free flow of cooling air. **NEVER** operate this equipment in any enclosed or narrow area where free flow of the air is restricted. If the air flow is restricted it will cause injury to people and property and serious damage to the equipment or engine.



- **NEVER** operate the equipment in an explosive atmosphere or near combustible materials. An explosion or fire could result causing severe **bodily harm or even death**.



WARNING

- **NEVER** pump corrosive chemicals or water containing toxic substances. These fluids could create serious health and environmental hazards. Contact local authorities for assistance.
- **NEVER** operate the pump with closed discharge hose. The liquid could reach boiling temperatures, build pressure, and cause the casing to rupture or explode.
- **NEVER** disconnect any **emergency or safety devices**. These devices are intended for operator safety. Disconnection of these devices can cause severe injury, bodily harm or even death. Disconnection of any of these devices will void all warranties.

SAFETY INFORMATION

CAUTION

- **NEVER** lubricate components or attempt service on a running machine.
- **NEVER** block or restrict flow from discharge hose. Remove kinks from discharge line before starting pump. Operation with a blocked discharge line can cause water inside pump to overheat.
- **DO NOT** operate this equipment unless the hopper grate, guards and safety devices are attached and in place.
- **CAUTION** must be exercised while servicing this equipment. Rotating and moving parts can cause injury if contacted.
- Keep hands out of the hopper when the engine is running.

NOTICE

- In winter drain water from the lubrication box to prevent freezing.
- **ALWAYS** be sure the operator is familiar with proper safety precautions and operation techniques before using pump.
- Keep all *inexperienced* and **unauthorized** people away from the equipment at all times.
- Before start-up, check the hopper and remove all foreign matter and debris.
- **DO NOT** use worn or damaged hose couplings, inspect all hoses and couplings for wear. Replace any worn or defective hose or couplings immediately.
- Unauthorized equipment modifications will void all warranties.
- Check all fasteners periodically for tightness. Also check towing tongue bolt, lock nut and wheel lug nuts for wear.
- Test the pump's **emergency stop** switch. The purpose of this test is to shut down the engine in the event of an emergency.

- Refer to the Perkins Engine Owner's Manual for engine technical questions or information recommended by Multiquip for this equipment. Damage to the equipment and or injury to user may result.
- **ALWAYS** remove the ignition key when leaving the pump unattended.
- **ALWAYS** block the wheels on the unit when using on a slope.
- **ALWAYS** use properly rated hoses and clamps — 1500 PSI or higher.
- **ALWAYS** allow the pump a proper amount of time to cool before servicing.
- **ALWAYS** keep the machine in proper running condition.
- **ALWAYS** ensure pump is on level ground before use.
- Fix damage to machine and replace any broken parts immediately.
- **ALWAYS** store equipment properly when it is not being used. Equipment should be stored in a clean, dry location out of the reach of children and unauthorized personnel.

ENGINE SAFETY

WARNING

- **DO NOT** place hands or fingers inside engine compartment when engine is running.
- **NEVER** operate the engine with heat shields or guards removed.
- **DO NOT** remove the engine oil drain plug while the engine is hot. Hot oil will gush out of the oil tank and severely scald any persons in the general area of the pump.



CAUTION

- **NEVER** touch the hot exhaust manifold, muffler or cylinder. Allow these parts to cool before servicing equipment.



SAFETY INFORMATION

NOTICE

- **NEVER** run engine without an air filter or with a dirty air filter. Severe engine damage may occur. Service air filter frequently to prevent engine malfunction.
- **NEVER** tamper with the factory settings of the engine or engine governor. Damage to the engine or equipment can result if operating in speed ranges above the maximum allowable.



FUEL SAFETY

DANGER

- **DO NOT** start the engine near spilled fuel or combustible fluids. Fuel is extremely flammable and its vapors can cause an explosion if ignited.
- **ALWAYS** refuel in a well-ventilated area, away from sparks and open flames.
- **ALWAYS** use extreme caution when working with **flammable** liquids.
- **DO NOT** fill the fuel tank while the engine is running or hot.
- **DO NOT** overfill tank, since spilled fuel could ignite if it comes into contact with hot engine parts or sparks from the ignition system.
- Store fuel in appropriate containers, in well-ventilated areas and away from sparks and flames.
- **NEVER** use fuel as a cleaning agent.
- **DO NOT** smoke around or near the equipment. Fire or explosion could result from fuel vapors or if fuel is spilled on a hot engine.



BATTERY SAFETY

DANGER

- **DO NOT** drop the battery. There is a possibility that the battery will explode.
- **DO NOT** expose the battery to open flames, sparks, cigarettes, etc. The battery contains combustible gases and liquids. If these gases and liquids come into contact with a flame or spark, an explosion could occur.

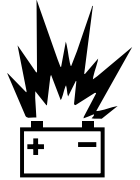

WARNING

- **ALWAYS** wear safety glasses when handling the battery to avoid eye irritation. The battery contains acids that can cause injury to the eyes and skin.
- Use well-insulated gloves when picking up the battery.
- **ALWAYS** keep the battery charged. If the battery is not charged, combustible gas will build up.
- **DO NOT** charge battery if frozen. Battery can explode. When frozen, warm the battery to at least 61°F (16°C).
- **ALWAYS** recharge the battery in a well-ventilated environment to avoid the risk of a dangerous concentration of combustible gases.
- If the battery liquid (dilute sulfuric acid) comes into contact with **clothing or skin**, rinse skin or clothing immediately with plenty of water.
- If the battery liquid (dilute sulfuric acid) comes into contact with **eyes**, rinse eyes immediately with plenty of water and contact the nearest doctor or hospital to seek medical attention.



CAUTION

- **ALWAYS** disconnect the **NEGATIVE** battery terminal before performing service on the equipment.
- **ALWAYS** keep battery cables in good working condition. Repair or replace all worn cables.

SAFETY INFORMATION

TRANSPORTING SAFETY

⚠ CAUTION

- **NEVER** allow any person or animal to stand underneath the equipment while lifting.

NOTICE

- Before lifting, make sure that the equipment parts are not damaged and screws are not loose or missing.
- **ALWAYS** make sure forklift forks are inserted into pockets (if applicable) as far as possible when lifting the pump.
- **ALWAYS** shutdown engine before transporting.
- **NEVER** lift the equipment while the engine is running.
- Tighten fuel tank cap secure to prevent fuel from spilling.
- Use one point suspension hook and lift straight upwards.
- **DO NOT** lift machine to unnecessary heights.
- **ALWAYS** tie down equipment during transport by securing the equipment with straps, rope or chains.

TOWING SAFETY

⚠ CAUTION

- Check with your local county or state safety towing regulations, in addition to meeting **Department of Transportation (DOT) Safety Towing Regulations**, before towing your generator. 
- In order to reduce the possibility of an accident while transporting the generator on public roads, **ALWAYS** make sure the trailer that supports the pump and the towing vehicle are mechanically sound and in good operating condition.
- **ALWAYS** shutdown engine before transporting
- Make sure the hitch and coupling of the towing vehicle are rated equal to, or greater than the trailer “gross vehicle weight rating.”
- **ALWAYS** inspect the hitch and coupling for wear. **NEVER** tow a trailer with defective hitches, couplings, chains, etc.

- Check the tire air pressure on both towing vehicle and trailer. **Trailer tires should be inflated to 80 psi cold.** Also check the tire tread wear on both vehicles.
- **ALWAYS** make sure the trailer is equipped with a **safety chain**.
- **ALWAYS** properly attach trailer’s safety chains to towing vehicle.
- **ALWAYS** make sure the vehicle and trailer directional, backup, brake and trailer lights are connected and working properly.
- DOT Requirements include the following:
 - Connect and test electric brake operation.
 - Secure portable power cables in cable tray with tie wraps.
- The maximum speed for highway towing is **55 MPH** unless posted otherwise. Recommended off-road towing is not to exceed **15 MPH** or less depending on type of terrain.
- Avoid sudden stops and starts. This can cause skidding, or jack-knifing. Smooth, gradual starts and stops will improve towing.
- Avoid sharp turns to prevent rolling.
- Trailer should be adjusted to a level position at all times when towing.
- Raise and lock trailer wheel stand in up position when towing.
- Place **chock blocks** underneath wheel to prevent **rolling** while parked.
- Place **support blocks** underneath the trailer’s bumper to prevent **tipping** while parked.
- Use the trailer’s swivel jack to adjust the trailer height to a level position while parked.

ENVIRONMENTAL SAFETY/DECOMMISSIONING

NOTICE

Decommissioning is a controlled process used to safely retire a piece of equipment that is no longer serviceable. If the equipment poses an unacceptable and unrepairable safety risk due to wear or damage or is no longer cost effective to maintain (beyond life-cycle reliability) and is to be decommissioned (demolition and dismantlement), be sure to follow rules below.

- **DO NOT** pour waste or oil directly onto the ground, down a drain or into any water source.
- Contact your country's Department of Public Works or recycling agency in your area and arrange for proper disposal of any electrical components, waste or oil associated with this equipment.
- When the life cycle of this equipment is over, remove battery and bring to appropriate facility for lead reclamation. Use safety precautions when handling batteries that contain sulfuric acid.
- When the life cycle of this equipment is over, it is recommended that the trowel frame and all other metal parts be sent to a recycling center.



Metal recycling involves the collection of metal from discarded products and its transformation into raw materials to use in manufacturing a new product.

Recyclers and manufacturers alike promote the process of recycling metal. Using a metal recycling center promotes energy cost savings.

EMISSIONS INFORMATION

NOTICE

The diesel engine used in this equipment has been designed to reduce harmful levels of carbon monoxide (CO), hydrocarbons (HC) and nitrogen oxides (NOx) contained in diesel exhaust emissions.

This engine has been certified to meet US EPA Evaporative emissions requirements in the installed configuration.

Attempting to modify or make adjustments to the engine emission system by unauthorized personnel without proper training could damage the equipment or create an unsafe condition.

Additionally, modifying the fuel system may adversely affect evaporative emissions, resulting in fines or other penalties.

Emission Control Label

The emission control label is an integral part of the emission system and is strictly controlled by regulations.

The label must remain with the engine for its entire life.

If a replacement emission label is needed, please contact your authorized Perkins Engine Distributor.

SPECIFICATIONS

Table 1. Pump Specifications

Model	LS-600P
Pumping Rate LS-600	Up to 60 cu. yds. per hour*
Pumping Method	Reciprocating Piston
Maximum Aggregate Size	1-1/2 in. minus (38mm)
Vertical Pumping Height	Up to 250 ft. (76m)
Piston Face Pressure	1100 PSI
Horizontal Pumping Distance	1000 ft. (305m)*
Cylinder Lubrication Box Capacity	2 Gallons (7.6 Liters)
Hydraulic Fluid Capacity	50 Gallons (189 Liters)
Fuel Tank Capacity	40 Gallons (76 Liters)
Hopper Capacity	10 cu. ft. with optional fwd/rev remixer
Material Hose	3 in., 4 in., 5 in. dia. (76.2mm, 101.6 mm, 127 mm)
Weight (with fluids)	5,190 lbs. (2,354 kg)
Weight (dry/shipping)	4,760 lbs. (2,159 kg)
Tire Size	16 in. (406 mm)
Option	Wireless Remote Control, Hopper Screen Vibrator
*Volume output will vary depending on mix design, slump, line size used and job site conditions.	

Table 2. Engine Specifications

Model	Perkins Turbo Diesel 1104D-44TA
Type	4 stroke, Water-Cooled Diesel
No. of Cylinders	4
Bore x Stroke	4.13 in. x 5 in. (105 mm x 127 mm)
Rated Output	108 HP@ 2200 rpm
Displacement	268.5 cu. in. (4.4 L)
Starting	Electric 12VDC
Lube Oil Capacity	2.08 gal. (2.5 liters)
Coolant Capacity/With Radiator	4.5 gal. (17 liters)
Fuel Type	#2 Diesel Fuel
Battery	12V BCI Group 27
Weight Dry	1,250 lbs. (567 kg)
Dimensions LxWxH in. (mm)	50 x 28.9 x 37.9 (1,269 x 734 x 964)

DIMENSIONS

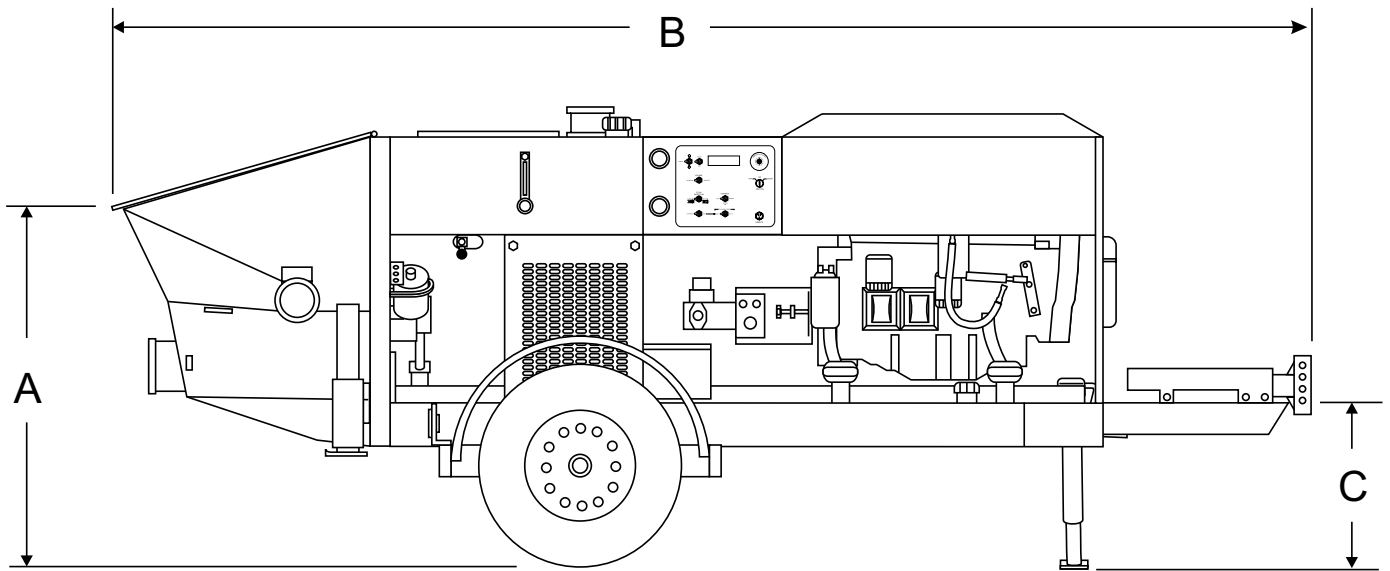

Table 3. Pump Dimensions	
Reference Letter	Dimensions in. (mm)
A	43 (1,092)
B	173 (4,394)
C	24 (610)
D	72 (1,828)
E	68 (1,727)

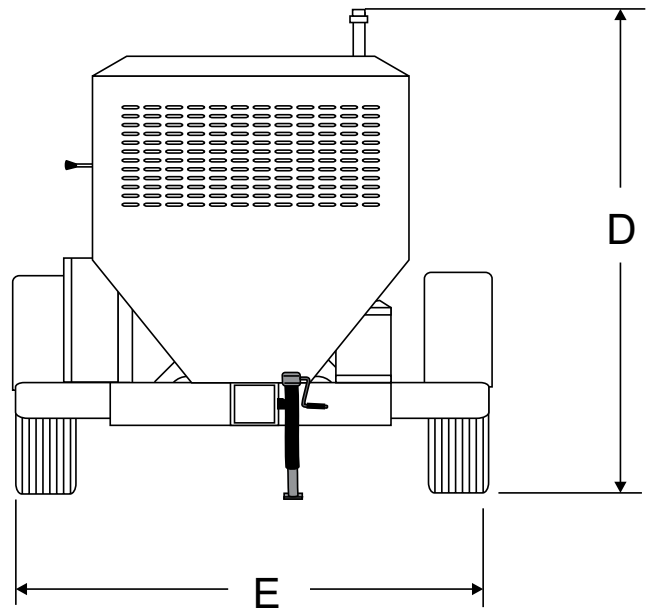

Figure 1. Dimensions

IMPORTANT HAND SIGNALS

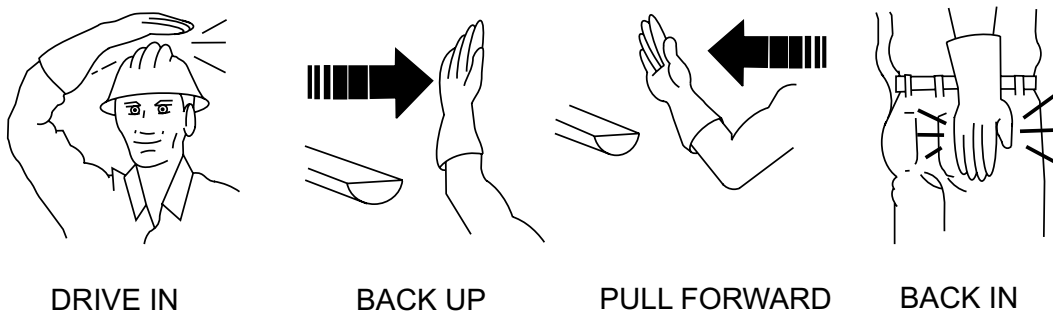
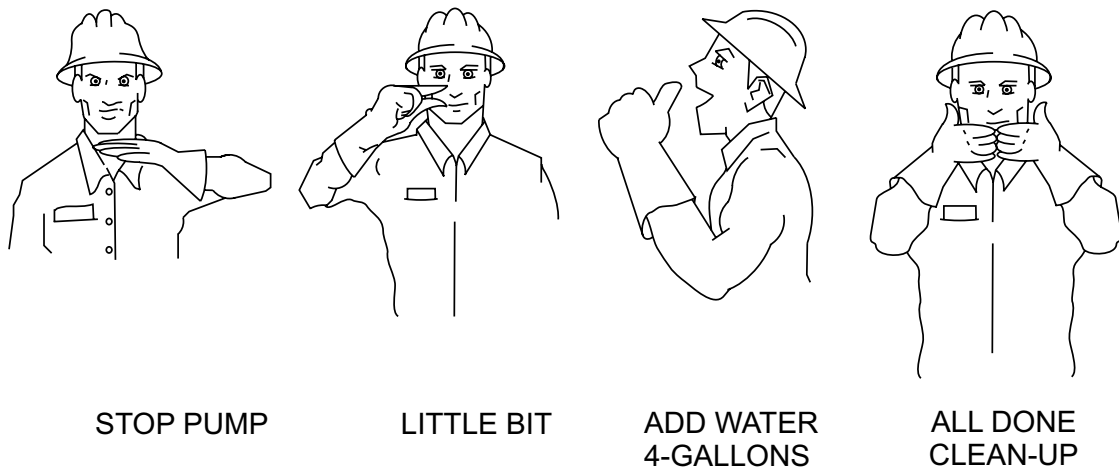
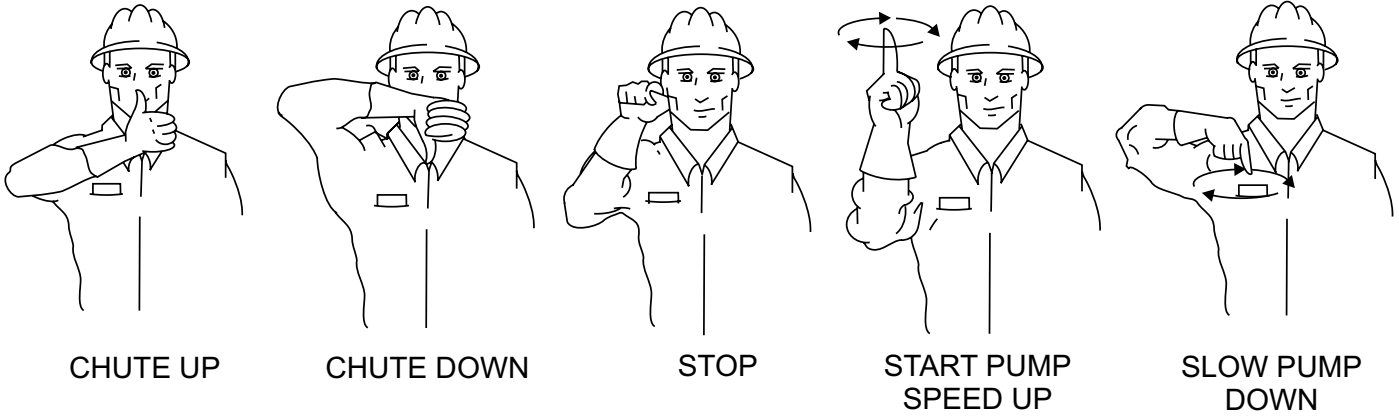

Figure 2. Operation Hand Signals

CONCRETE MIX DESIGN

Mix design is most important to achieve maximum pumpability. Pumpability is affected by, among other factors, the type and gradation of aggregate used. Natural aggregates make a more workable mix and pump more readily than crushed aggregates. A blend of natural and crushed aggregates will produce a workable mix. The type and gradation of aggregates is equally important for workability as the size and percentage of coarse aggregates in the mix.

The term “aggregates” describes all of the solid materials, from the largest rock to the smallest grain of sand, contained in the concrete mix.

Concrete mixes with a consistency as dry as one-inch slump and as wet as ten-inch slump have been pumped; but for maximum efficiency from the pump, a slump ranging from two to six inches will produce a more workable mix than one that contains more or less water.

The principle of concrete pumping is based on self-lubrication. As it moves through the transfer line, the concrete takes the shape of a plastic cylinder. It is forced through the transfer line on a film of mortar that is self-troweled to the service of the transfer line around its full periphery by the slug of concrete itself.

A slump rating should be used with discretion; it is not always a real indication of the pumpability of the mix. The concrete may be workable in the sense that it will readily flow into place, but the same mix may not respond to pressure.

Overly wet mixes tend to separate. In addition to affecting the strength and quality of the concrete, the delivery system will not tolerate separation. Overly dry mixes are similarly unsatisfactory if they lack plasticity and tend to be crumbly. To be properly pumped, the mix must be able to continuously coat the inside of the line with a lubricating seal of mortar.

There are four ways in which this seal can be lost:

1. By pumping excessively wet mixes which do not have enough cohesion to hold together.
2. By pumping harsh undersanded concrete with poorly graded aggregates which can jam together when the pressure becomes too great for the insufficient amount of sand to hold the aggregates apart.

3. By getting a rock pocket, such as mixer tailings, into the pump valve. This rock pocket will have an insufficient coating of mortar and the mix will not be plastic enough to allow the valve to operate or the mix to move in the line.
4. Through excessive bleeding. If the mix is short or fines, but the sand is otherwise fairly well graded, bleeding will not normally create any problems as long as the pump continues operation. But, if the pump is shut down, bleeding can result in a loss of lubrication and blocked erratic flow.

The above are bad concrete practices, regardless of how the mix is to be placed. But, these points do show that special mixes are not always needed, within limits, for pumping concrete. Good aggregate gradation is most important to pump concrete the maximum distance.

The use of admixtures can have a beneficial effect on pumpability. Most of the dispersing agents will fatten, retard bleeding, and increase workability. Thus, the average concrete can be pumped for appreciably longer distances. Air entraining agents will also improve workability, although they cannot be used as a substitute for good gradation of the aggregate.

Pumping will not appreciably affect the final air content of the mix. High-early cement tends to give a more readily pumpable mix with superior water retaining qualities. However, if delays are likely to occur, extra care must be exercised due to the faster setting time over regular cement.

The Mayco LS600P will pump a wide variety of concrete pump mixes. But, there are guidelines that must be followed. Use this information in conjunction with the Operation section of this manual.

GENERAL INFORMATION

REGIONAL DIFFERENCES

Concrete is made by mixing locally available rock and sand with cement and water. For this reason there are great differences in the pumpability of concrete from one region of the country to another.

It is impossible to define a specific mix for each region that the concrete pump be will working in. Therefore, the mixes listed in Appendix - Concrete Mix Information will provide a basic guideline for establishing the proper mix design for your area.

Use this information to specify your requirements to your local ready-mix batch plant, contractor and civil engineer. It may take minor adjustments to make a mix pumpable, so you should explain your needs.

The elements that have to be controlled and consistently maintained by the batch plant are:

1. The sizing and mix percentage of rocks, gap graded from the largest down through the smallest sizes.
2. Sand with a sieve analysis that has the proper percentage of fines, ASTM C33 spec.
3. Sufficient cement to produce the required design strength of the concrete and provide the lubricating binder to pump the concrete through the delivery system.

Use a minimum of:

- 500 lbs. of cement/cu yd for 2500 p.s.i. concrete after 28 days.
 - 530 lbs. of cement/cu yd for 3000 p.s.i. concrete after 28 days.
 - 600 lbs. of cement/cu yd for 4000 p.s.i. concrete after 28 days.
4. Admixture pump-aid if necessary.
 5. The proper amount of water to make a workable slump and plasticize the mix.

In addition, this Mayco Concrete Pump can be used to pump a large aggregate hard rock as follows:

- Pea rock (1/2" minus) pump with mixes being as low as 30% rock and 70% sand. (reference maintenance for recommendations on cleaning the pump.)
- Shortening pea rock when used with an air compressor and nozzle.
- "Mud Jacking", high pressure grouting.

PUMPING INFORMATION

Remixtures

Remixtures that are designed into the concrete mix by the redi-mix company or an architectural engineering company. This section lists common admixtures and a brief explanation of their functions:

1. **Pozzolith 300** — Or the equivalent acts as a water retarder and a lubricant. On a lean mix, long pushes, stiff mixes, and vertical pushes, Pozzolith 300R helps pumpability.
2. **MBVR** — Air entraining, acts as a lubricant.
3. **Calcium Chloride** — Commonly referred to as C.C., is used as an accelerator. When pumping a load with calcium chloride, it is recommended that you wash out if the waiting time between delivery trucks becomes too long.
4. **Super Plasticizers** — Acts as an accelerator. The concrete will look very wet after the super plasticizer is added, but will begin to set up very fast. Wash out immediately if you do not have a truck waiting. Super plasticizers are used mainly on commercial jobs.
5. **Red Label** — Acts as a water retarder and an accelerator. Red label will be used mainly on commercial jobs.
6. **Fly Ash** — Is used to help increase the strength of the concrete and decrease the cement content per yard. This is one of the most common admixtures used.

NOTICE

All admixtures will be shown on the redi-mix concrete ticket. Before starting the pumping job, ask the driver of the redi-mix truck to see the concrete ticket and note the admixtures that exist and take the proper action.

Downhill Pumping

Downhill pumping can be a difficult procedure on some jobs. The slurry procedure would be the same as explained *Priming The Pump With Slurry Mixture* section of this manual. It is suggested that a sponge approximately 2"x 4"x 6" in size be placed in the hose before the start of pumping.

Wet the sponge before placing it in the hose to keep the slurry from running too far ahead of the concrete, which will reduce the possibility of separation. When the pump is stopped, the material can flow slowly down, due to gravity, and cause the hose to collapse.

When pumping is resumed, you can expect blockage at the point of hose collapse. To prevent this from happening, the hose can be "kinked off" at the discharge end when the pump is stopped to prevent the gravity flow of the material in the hose.

The use of stiffer mixes when pumping downhill will decrease gravity flow of the material in the hose and will assure a smoother operation between the cam roller bearing and cam plate. As with any job, make sure that the hose and the couplings are in good workable shape.

Vertical Pumping

When pumping vertically up the side of a building, above 40 feet, we would recommend the installation of steel pipe securely fastened at intervals as necessary to support the pipe. Ninety degree, long radius pipe sweeps should be installed at the top and bottom of the steel line.

Use a 25 ft. hose, or short section, off the pump; and for the balance of the horizontal distance to the vertical line, use steel pipe. This type of installation has been satisfactory on many jobs being pumped in excess of 100 feet high. Line pressures are always less using steel pipe as compared to hose.

When pumping vertically, using all hose, it is recommended not to go higher than 50 feet with hose. The hose should be tied off at intervals of 10 feet, if possible. Special attention should be given when tying the hose off at the top as the hose will have a tendency to stretch when filled with concrete. This will increase the possibility of a blockage at the point where the hose is tied off. To avoid this, a long radius of 90° elbow is recommended. The suggested place to tie off is on the hose, under the clamp.

NOTICE

It is strongly recommended that steel pipe be used on all vertical pumping for safety and convenience.

Hose Pulsation

A slight pulsation of the hose will always be noticeable near the pump. Excessive pulsation of the hose near the pump is normally due to higher than average line pressures caused by stiff, harsh mixes, or extremely long pumping distances.

The use of 2 -1/2" I.D. hose in these extreme cases reduces line pressures or the addition of slight amounts of water to the mix, if permissible, will permit easier pumping. The use of certain pumping admixtures may help.

If excessive pulsation exists in the hose, it is advisable to use burlap or some means of wear protection under the hose at points where the hose may wear through the outer cover; e.g. over forms, steel or sharp curbs.

Snap-Joint Couplings

When using Snap-Joint couplings with gaskets to join hose, see that they are washed clean after each job. Keeping the hose ends clean (heavy duty) is very important for the best job setup. A thin coat of grease on the rubber gasket or dipping both coupling and gasket in water before coupling the hose will make for easier installation.

GENERAL INFORMATION

Fill the hopper with water after making sure that all sand and rock have been removed from manifold. Operate pump at full throttle and the 3/8" diameter hole restriction will create sufficient back pressure to make thorough inspection of all moving parts.

The Effects Of Heat And Excessive Time On Concrete:

Hot concrete, commonly referred to as a hot load, is concrete that has been in the redi-mix truck in excess of 2 to 3 hours. On a hot day, this amount of time is even less.

A brief explanation of why heat and time affect concrete:

Concrete starts setting by drying up through a chemical reaction. The catalyst to this reaction is heat. When pumping a hot load, it is important to remember that when you have to stop pumping for any reason, add water to the concrete in the hopper and hand mix and move concrete in the hose every 5 minutes. If the shut down time becomes too long, wash out immediately.

If it is necessary to wait 1/2 hour or more for another load of concrete, to prevent setting of the mix in the system, it is advisable to consider the following factors (A through D) affecting the concrete:

- How old is the concrete?
- Is there an accelerator, calcium chloride, red label, etc., in the concrete?
- The temperature of the day, 80, 90, degrees?
- How much system you have out and how stiff was the mix you were pumping?

Preventing Mix Set-Up After Pump Shutdown

When the pump is stopped for any reason during a pour; e.g., moving hose, waiting for redi-mix truck, the following suggestions are offered:

1. Leave the hopper full of concrete at the time of shutdown. It is important not to let the redi-mix driver wash too much water into the hopper, as this could cause separation of the concrete in the hopper.
2. If the shutdown period exceeds 2 to 3 minutes, turn off the engine so the vibration does not separate the mix in the hopper which can cause a blockage in the manifold when the pump is started.

3. If it is necessary to wait 10 minutes or more for another load of concrete, it is wise to start the pump and pump 6 or 8 strokes every 5 minutes to prevent setting of the mix in the system. If waiting time is excessive, it would be wise to wash out the pump and hoses and start over when the new truck arrives.
4. When pumping stiff mixes and there is waiting time between redi-mix trucks, it is advisable to add some water to the last hopper of material and "hand mix" to ensure an easier start with the following load.
5. When the pumping job requires a stiffer mix, the following method is suggested for starting: Take a water hose with a nozzle on it and apply water with a fine spray to the concrete as it comes down the redi-mix chute into the pump hopper after the slurry procedure is completed and you are ready to start pumping.
6. Using this procedure will make it easier to pump through the clean hose.

NOTICE

Once the concrete has reached the end of the hose, **DO NOT** apply any more water in this manner as this procedure is used for starting only.

7. Hose sizing is very important: We strongly recommend on harsh mixes, vertical pushes, stiff concrete, shotcrete, long pushes, that a 2-1/2" line be used as far as possible. The advantages of using the 2-1/2" line are improved pumpability, less pumping pressure and less wear on the pump.
8. Following the pump operation, proper wash out of all materials or "build-up" within the pump manifold and hoses will prevent problems when starting the next job.
9. A thorough inspection of the drive components and greasing of all bearings after each job will ensure adequate lubrication and service to the pump which is normally operating in wet, gritty conditions.

NOTICE

Over-greasing any bearing on your Mayco pump will not damage the bearing.

GENERAL INFORMATION

Clearing The System After Mix Set Up

If, for any reason, the mix should set up in the system, the following procedure is suggested:

1. Disconnect the hose from the pump and wash the pump out immediately.

WARNING

Hose Line Pressure

When disconnecting hoses, use extreme **CAUTION**. The hose is under pressure. Hose could whip and cause severe bodily harm.

2. Reconnect the hose and fill the hopper with water.
3. Reconnect the hose and fill the hopper with water. **DO NOT** try to push all the concrete out of all of the hose lines at one time.
4. For example: If you had 200 ft. of system out, you would disconnect each hose. Clean it out by pushing water through the first hose connected the pump, then continue progressing through all the hoses, until all the system is clean.
5. If waiting time is excessive, it would be wise to wash out the pump and hoses and start over when the new truck arrives. This can be avoided by being observant to the pump and system, also taking into consideration the above actors (A through D) affecting the mix.

Clearing Concrete Blockage

NOTICE

If you repeatedly pull the throttle all the way out and try to force your pump to push through blockages due to separation of material in the hose or manifold, you will soon have breakdowns and costly repairs which are not covered under warranty.

If a blockage occurs, find where it is and clear it before further pumping. **DO NOT** increase the engine speed to clear the blockage. Increasing the engine speed will only compound the problem.

If a blockage occurs in a hose, walk the hose until you find the point of trouble. The hose will be soft immediately past the blockage. To clear the blockage:

1. Disconnect the hose at the first coupling past the blockage. Be careful when disconnecting hose. Hose is under pressure. Hose could whip and cause severe bodily harm.
2. Elevate the hose at that point with the blockage area hanging down.
3. Using a hammer, you can pound the downstream edge of the packed area until it is free to flow. Shake all of the sand and gravel out to the end of the hose.
4. Before reconnecting the hose, start the pump and run a small amount of concrete out to the end of the hose. This will assure that all of the separation is out of the hose.

NOTICE

Damaged hoses with internal restrictions can cause blockages.

Clearing Shuttle Tube Blockage

The shuttle tube is plugged if volume at the discharge end of the hose stops and the hydraulic oil pressure gauge reads 4400 psi or more.

To clear a plug in the shuttle tube, great care must be taken as a dangerous condition will exist from pressure build-up inside the shuttle tube. With the shuttle valve, the concrete can be pumped in reverse. Use the following procedures to clear the shuttle tubes.

WARNING

Joint Clamps

DO NOT open any of the delivery system joint clamps during operation. The clamps are under pressure. The clamps, if opened during operation could allow high pressure material to escape and cause severe bodily harm.

GENERAL INFORMATION

Reverse Pumping Procedure

1. Switch the pump into reverse. With pump speed at a medium-slow (approx. 12 strokes per min.) try to pull the “pack” back into the hopper with 5 or 6 reverse strokes.
2. Remix the concrete in the hopper.
3. Switch the pump into forward. If it is still plugged, repeat “Reversing” procedure three times.
4. If concrete still does not move, proceed to the Shuttle Tube Inspection Procedure.

Shuttle Tube Inspection Procedure

! DANGER

Accumulator Pressure

Make sure the accumulator pressure gauge reads **ZERO** psi. prior to performing any maintenance or inspection. You must follow lock out-tag out procedures. Improper accumulator pressure can result in an explosion causing serious injury or **death**.

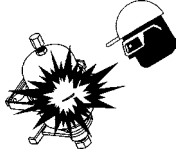

6. Remove the reducer. From the discharge end, chip the concrete out of the shuttle tube with the pry-bar. If concrete cannot be loosened from the outlet of the shuttle tube, remove the clean-out plug on the bottom of the hopper to discharge the concrete.
7. Chip the blockage out with the pry-bar.
8. Flush the shuttle tube with water.
9. Before resuming operation of the pump, perform the “Reverse” Pumping Procedure to relieve pressure on the shuttle tubes.

1. Stop the pump. Turn off the engine.
2. The senior or most experienced operator must warn all others to stand at least 20 feet away from the machine and turn their heads to face away from the pump.
3. The operator will position himself beside the reducing elbow at the pump outlet. Wearing safety glasses, slip the end of a pry bar (24" length of reinforcing steel rod) under the latch of the hose clamp and flip it up.
4. Carefully knock the end of the hose away from the reducer.
5. Chip the concrete out of the reducer with the pry bar.

GENERAL INFORMATION

The following is a brief explanation of how the concrete cylinders, hydraulic cylinders, shuttle tube, valves and hopper work in sequence to pump concrete.

The hydraulic pressure is generated by a variable volume, pressure compensated, axial piston pump that is driven by a diesel engine. The rod sides of the drive cylinders are hydraulically connected together creating a “slave circuit,” which allows hydraulic oil to transfer from one piston to the other.

The two part cycling sequence is initiated by an electrical signal generated by two proximity switches activated by the drive cylinder. The proximity switches are normally open, magnetically sensing the movement of the main drive cylinder. As the drive cylinder piston head passes the proximity switch, an electrical signal is sent to the solenoid operated pilot valve which in turn directs pilot oil to the four valves controlling the drive cylinder and the shuttle cylinder.

A one-gallon accumulator assists the movement of the shuttle tube. This circuit assures that the shuttle tube will throw with the same intensity of each stroke regardless of how fast the main drive cylinders are cycling.

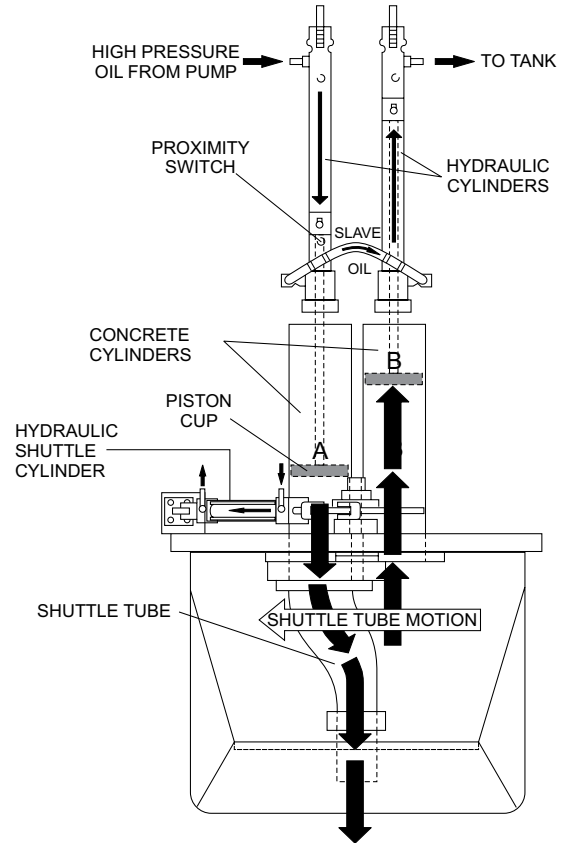

Figure 4. Pumping Cycle 2

In the first cycle (Figure 3), hydraulic pressure is applied to cylinder (B), causing the hydraulic piston, which is connected to the concrete piston and piston cup, to discharge concrete into the delivery line.

As one cylinder is discharging concrete, the hydraulic oil from the rod side (B) of the drive cylinders is being transferred through the slave circuit causing the opposite cylinder (A) to move back on the suction stroke, filling the cylinder with concrete.

The shuttle tube is sequenced to pivot to each concrete cylinder as the drive cylinders stroke to push concrete. As the second cycling sequence begins (Figure 4), the shuttle tube pivots to the opposite cylinder (A).

The hydraulic piston passes under the proximity switch and sends pressure to the piston, causing it to stroke and discharge concrete into the delivery line. Hydraulic oil is transferred through the slave circuit to cylinder B, causing it to start a suction stroke, refilling it with concrete. The pumping sequence then repeats for the duration of the operation.

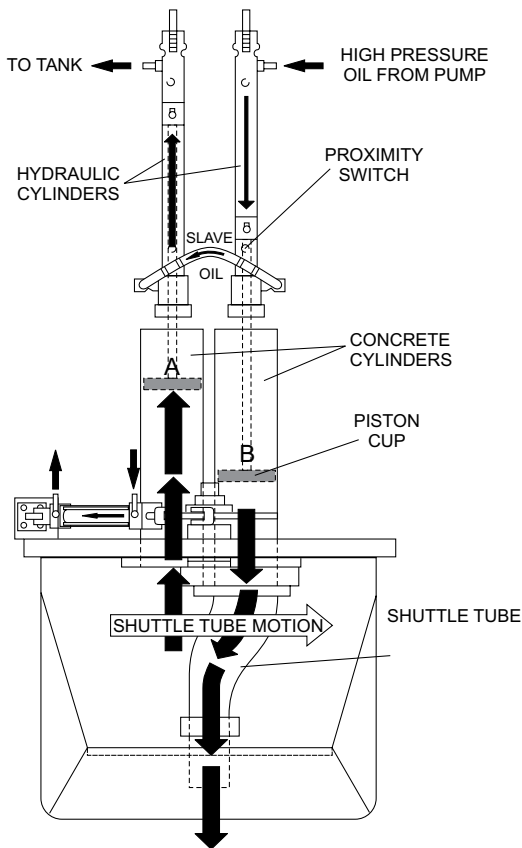

Figure 3. Pumping Cycle 1

PUMP COMPONENTS

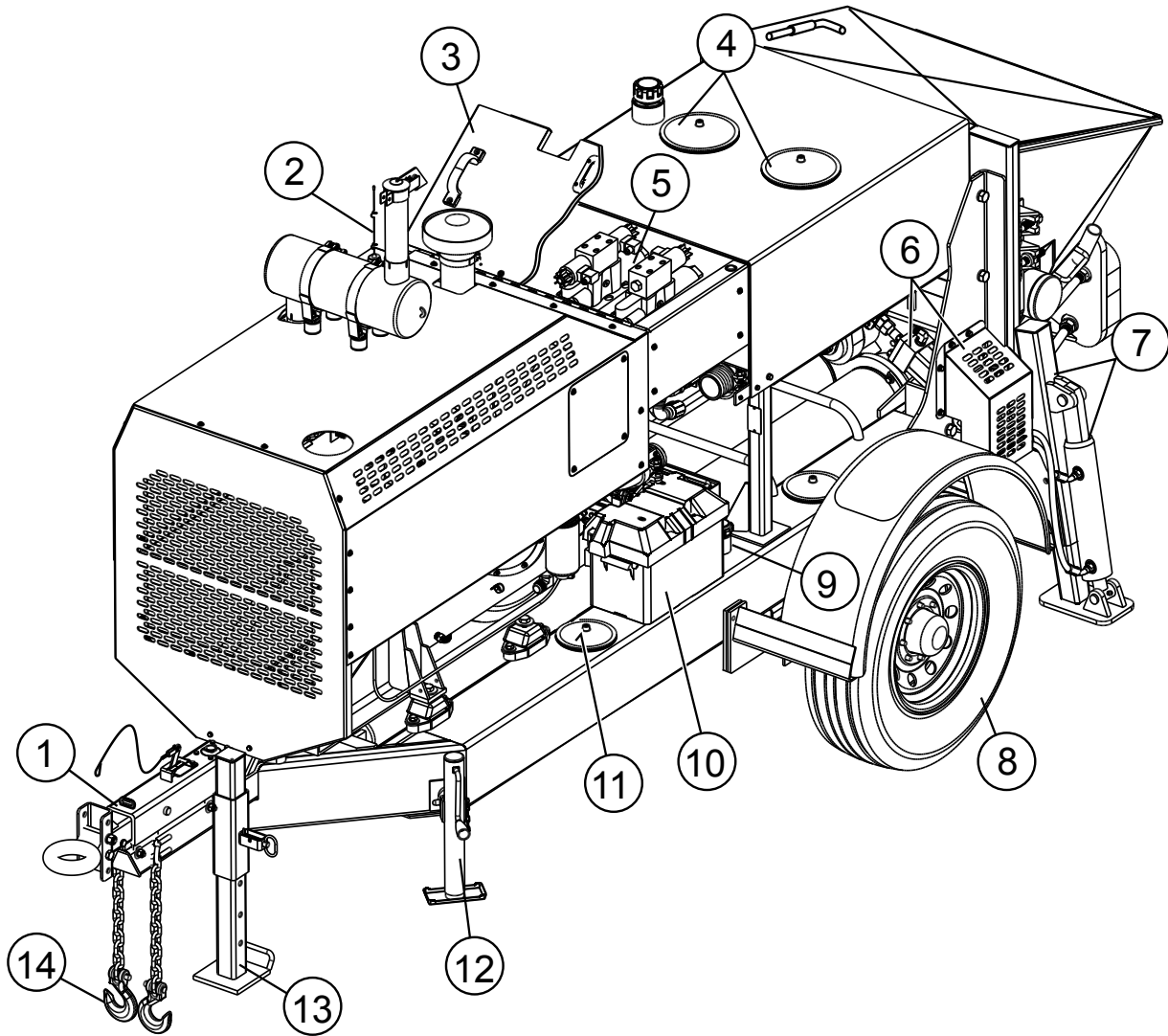

Figure 5. Pump Components (View 1)

PUMP COMPONENTS

Figure 5 and illustrates the location of the major components for the LS600P Concrete Pump. The function of each component is described below:

1. **Tow Hitch Coupler** — Requires a 2-inch ball hitch or a 3-inch pintle. Capable of towing 8,000 lbs.
2. **Radio Control Antenna** — Mounting location for radio control antenna. Works in conjunction with hand-held radio remote (option).
3. **Manifold Access Door** — Release latch and lift door to access the hydraulic manifold block.
4. **Hydraulic Oil Reservoir Access Cover** — Remove this cover to gain access to the hydraulic oil tank for maintenance/cleaning.
5. **Hydraulic Manifold Block** — Manifold block that controls the flow of hydraulic pressure to the components required to control the pump.
6. **Shuttle Cylinder/Guard** — Under pressure, the shuttle cylinder shears concrete passing from the concrete cylinder to the delivery line during the cycle phase. **ALWAYS** keep hands clear from shuttle cylinder during operation.
7. **Rear Pumping Jack Stand** — Use this jack stand to level and support the rear end of the pump during operation. **NEVER** deploy on un-level ground and always check for firmness of ground.
8. **Tires** — This trailer uses two ST235/80R16 type tires. Tire inflation pressure is the most important factor in tire life. Pressure should be checked to 80 psi cold before operation. **DO NOT** bleed air from tires when they are hot. Check inflation pressure weekly during use to insure the maximum tire life and tread wear.
9. **Fuel Tank/Cap** — Fill with diesel fuel. Fuel tank (cell) holds approximately 40 gallons (176 liters). **DO NOT** top off fuel. Wipe up any spilled fuel immediately.
10. **Battery** — This unit uses a +12 VDC type battery. **ALWAYS** use gloves and eye protection when handling the battery.
11. **Fuel Tank (Cell) Access Cover** — Remove this cover to gain access to the fuel tank for maintenance/cleaning.
12. **Parking Jack Stand** — Use this jack stand to level and support the tow end of the pump.
13. **Front Pumping Jack Stand** — Use this jack stand to level and support the rear end of the pump during operation. **NEVER** deploy on un-level ground and always check for firmness of ground.
14. **Safety Chains** — This pump uses 5/16-inch thick, 72 inches long zinc-plated safety chains. **ALWAYS** connect safety chains when towing.

PUMP COMPONENTS (CONTINUED)

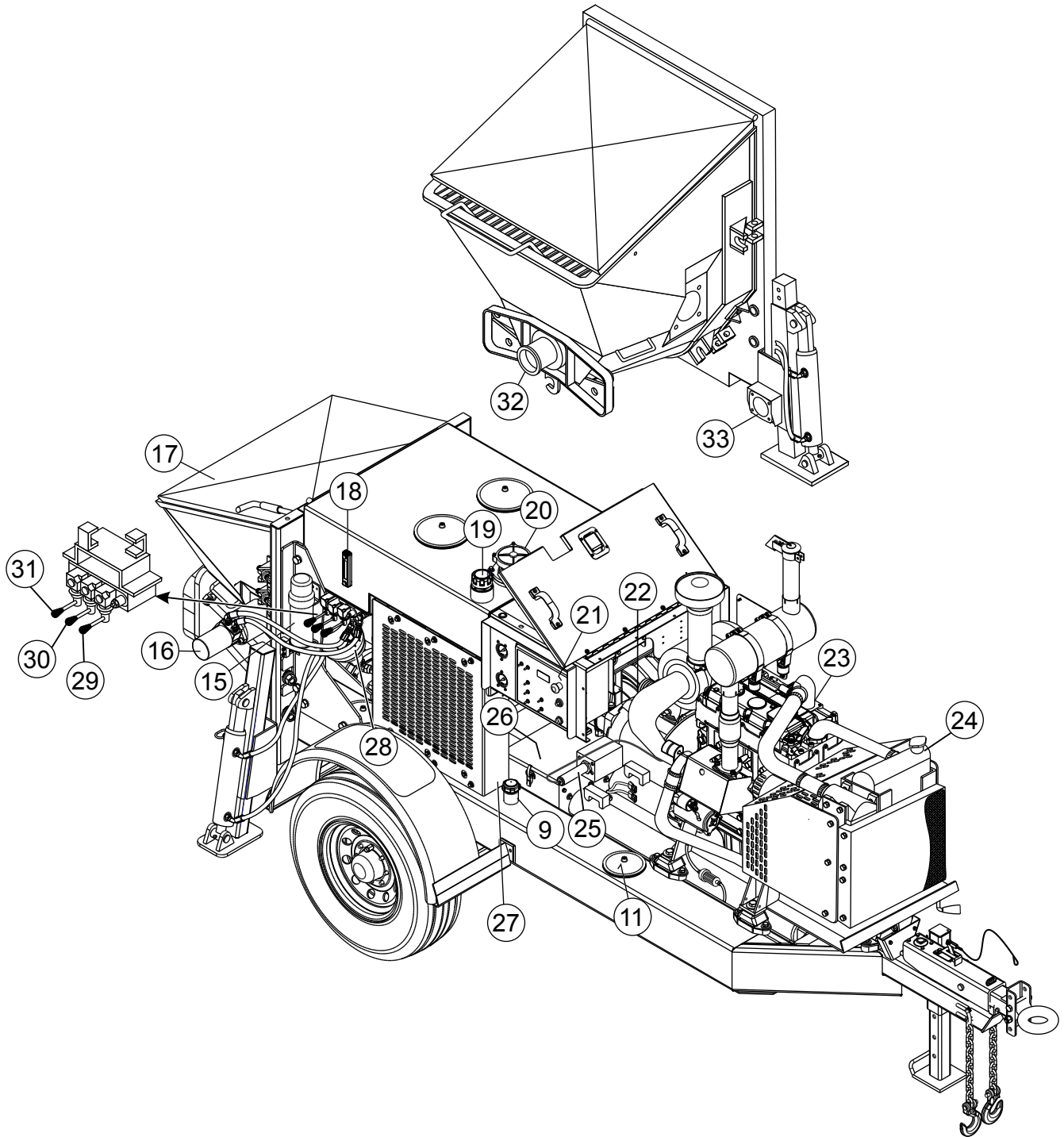

Figure 6. Pump Components (View 2)

PUMP COMPONENTS (CONTINUED)

Figure 6 illustrates the location of the major components for the LS600P Concrete Pump. The function of each component is described below:

15. **Documentation Box** — Contains engine and pump operation, parts and maintenance information.
16. **Remixer Motor** — Drives the remixer paddles inside the hopper. The motor direction is controlled by the remixer control lever.
17. **Hopper/Hood** — Lift hood to fill. Concrete from a Redi-Mix truck is poured into this hopper. The hopper can hold 10 cu. ft of concrete with optional forward/reverse mixer. **NEVER** put hands or any other parts of you body into the hopper.
18. **Hydraulic Oil Sight Glass** — Use to determine the amount of hydraulic oil remaining in tank. The sight glass also contains a temperature gauge for monitoring the temperature of the hydraulic oil.
19. **Hydraulic Oil Tank/Cap** — Remove cap to add hydraulic fluid. Fill with Shell Oil Tellus 68 or Mobil Oil DFE26 if level is low.
20. **Hydraulic Oil Filter** — This in-tank return hydraulic filter with a 10 micron cleanable filter is designed to remove all particles large enough to cause wear and job break down. Under normal conditions, replace every 6 months.
21. **Control Box** — Contains the electrical components required to run the pump. See control box components section for component callouts.
22. **Hydraulic Pump** — This unit incorporates an axial variable displacement hydraulic piston pump.
23. **Engine** — Perkins 1104D-44TA Turbo Diesel engine.
24. **Radiator** — Fill only with recommended coolant. Radiator coolant capacity is 4.5 gallons (17 liters).
25. **Volume Control** — This device is electronically controlled by the cylinder stroke switch located on the front panel of the control box. The function of the volume control is to set the pumping stroke.
26. **Lubrication Box** — This box is empty when shipped from the factory. Please fill with 3 gallons (11.35 liters) of SAE 30 motor oil for first time use. Also check the dual clean-out point on bottom of lubrication box for a secure tight fit.
27. **Heat Exchanger** — The function of the heat exchanger is to cool the hydraulic oil when pumping in high temperature weather conditions. The exchanger draws oil from the hydraulic tank through a filter and into the heat exchanger before allowing it to flow into the hydraulic system.
28. **Accumulator** — Stores hydraulic oil under pressure and releases it to the shuttle cylinder and provides the pressure needed to ensure enough force is provided during cycle.
29. **Hydraulic Stabilizer Control Lever (Right)** — This feature is an *option*. Push the lever downward to extend the left hydraulic stablizer. Push the control lever upward to retract the stablizer.
30. **Hydraulic Stabilizer Control Lever (Center)** — This feature is an *option*. Push the lever downward to extend the right hydraulic stablizer. Push the control lever upward to retract the stablizer.
31. **Remixer Control Lever (Left)** — Controls the forward/reverse motion of the hopper remixer paddles.
32. **Hopper Discharge Sleeve** — Connect hoses or steel pipes to the discharge sleeve for pouring concrete.
33. **Rear Running Lights** — **ALWAYS** check and make sure both the right and left running lights are functioning correctly before towing the pump

DIGITAL CONTROL PANEL COMPONENTS

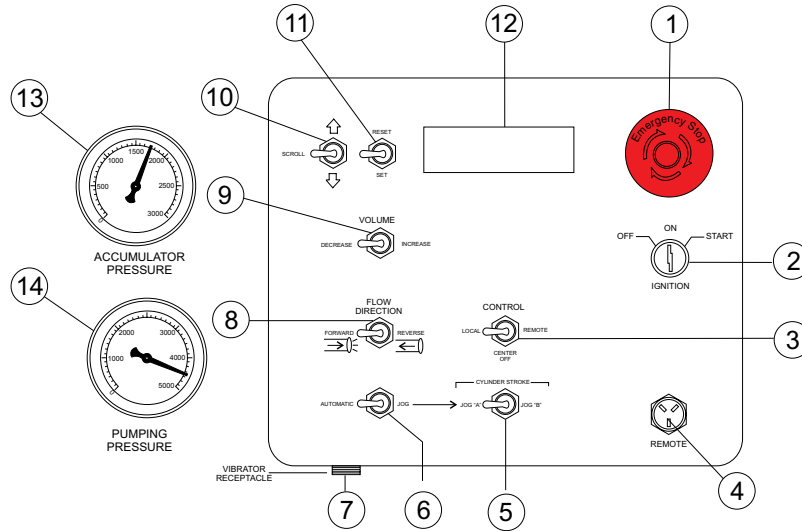

Figure 7. Pump Digital Control Panel Components

Figure 7 displays the components associated with the digital control panel. A brief description of each component is described below

1. **Emergency Stop Button** — Press emergency stop button to stop pump in an emergency. Turn knob counterclockwise to disengage the stop button.
2. **Ignition Switch** — Insert the ignition key here to start the engine. Turn the key clockwise to the **ON** position, then continue turning clockwise to the **START** position and release. To stop the engine turn the key fully counterclockwise to the **STOP** position.
3. **Pumping Control Switch** — This 3-position switch controls the pumping of the pump. The rightmost position (**REMOTE**) is for use with the remote control unit, the leftmost position (**LOCAL**) is for normal pumping operation, and the centermost position (**CENTER OFF**) prevents pumping.
4. **Remote Cable Receptacle** — Insert the remote control cable into this receptacle.
5. **Manual Cylinder Jogging Switch** — This 2-position switch allows the operator to manually jog the cylinders to assist in clearing material line packs and is used to test pumping pressure (See Initial Start-up Procedure section of this manual for testing procedure).
The **leftmost** position jogs cylinder “**A**” and the **rightmost** position jogs cylinder “**B**”.
6. **Cylinder Stroke Control Switch** — This 2-position switch controls the pumping function. The leftmost position (**AUTOMATIC**) sets the pump to automatic cycling. Set the switch to this position for normal pump operation.

The rightmost position (**JOG**) changes the pump from automatic to manual cycling. This allows the cylinders to be manually cycled using the **manual cylinder jogging switch**.

7. **Vibrator Cable Receptacle (Option)** — Insert the vibrator cable into this receptacle.
8. **Direction Control Switch** — This 2-position switch controls the direction of flow for any mix in the pump. The leftmost position sets the pumping direction to forward and the rightmost position sets the pumping direction to reverse.
9. **Stroke Volume Control Switch** — Increases or decreases the number of strokes per minute of the pump.
10. **Scroll Switch** — Allows the operator to scroll the various readout screens.
11. **Reset Switch** — Allows the operator to reset the stroke counter.
12. **Digital Readout Screen** — Displays and monitors the various functions of the machine.
13. **Accumulator Pressure Gauge** — This gauge monitors the internal pressure of the Accumulator tank. Normal internal pressure should read approximately 1750 PSI during pumping.
14. **Main Pressure Gauge** — This gauge monitors the system pressure while pumping material. The maximum pressure rating is 4400 ~ 4400 PSI.

DIGITAL CONTROL PANEL COMPONENTS

PRIMARY SCREEN

Screen 1

Indicates the various modes of the switch settings. Monitors engine RPM - Idle speed 900, High speed 2350. Battery charge indicator - Normal charge 13+ volts. Indicates electrical malfunction - Refer to Troubleshooting section.

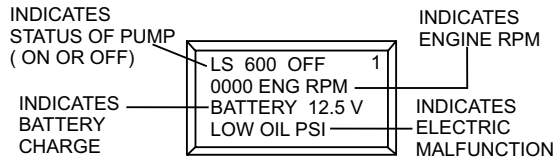

SECONDARY SCREENS

Screen 2

Displays the position of the **VOLUME CONTROL** switch by indicating whether the increase or decrease position is on or off.

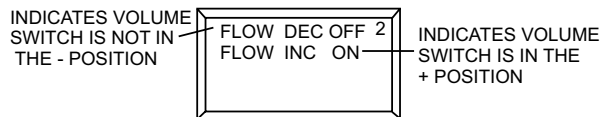

Screen 3

Displays the number of hours the engine and pump have been used and the number of faults the pump has registered. All three indicators can be reset to zero by the **RESET** switch on the control panel.

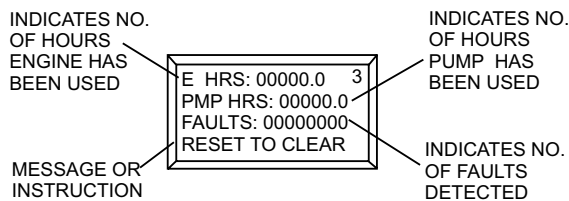

Screen 4

Displays the number of strokes the main hydraulic cylinders have gone through. This indicator can be reset to zero by the **RESET** switch on the control panel.

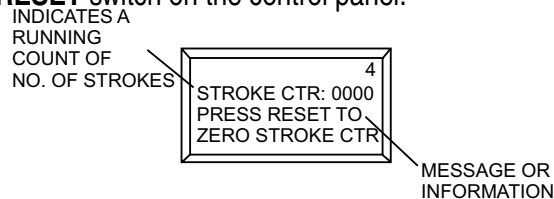

Screen 5

Displays the ON/OFF electrical signal status of the various 12 volt solenoids (Swing A circuit, Main A circuit, Main B circuit).

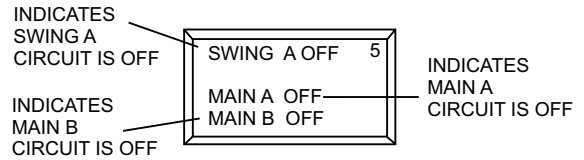

Screen 6

Displays the ON/OFF electrical signal status for the Proximity Switch A, Proximity Switch B, Engine Fuel Solenoid, and Unloader Solenoid.

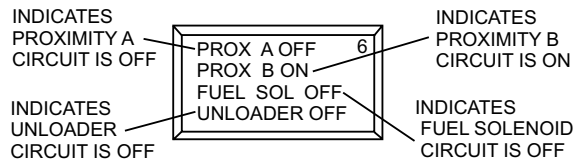

Screen 7

Displays the number of times the main hydraulic cylinders stroke and the yards per hour output. This indicator can be reset to zero by the **RESET** switch on the control panel.

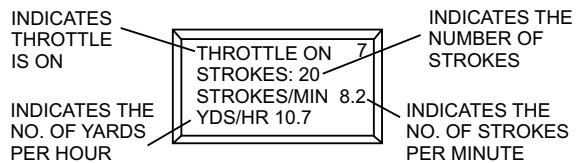

Screen 8

Displays the electrical status of the engine fuel solenoid. To test the 12-Volt solenoid status, activate with the **RESET** switch on the control panel.

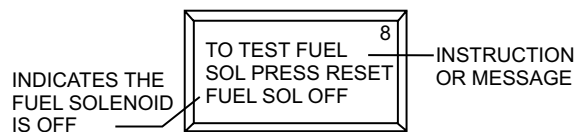

Screen 9

Displays the communication status of the (optional) radio remote control. To activate a new remote control connection, use the reset switch on the control panel.

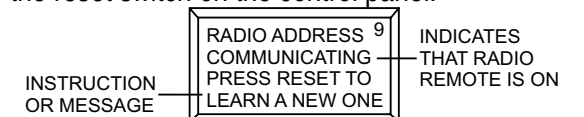

ENGINE COMPONENTS

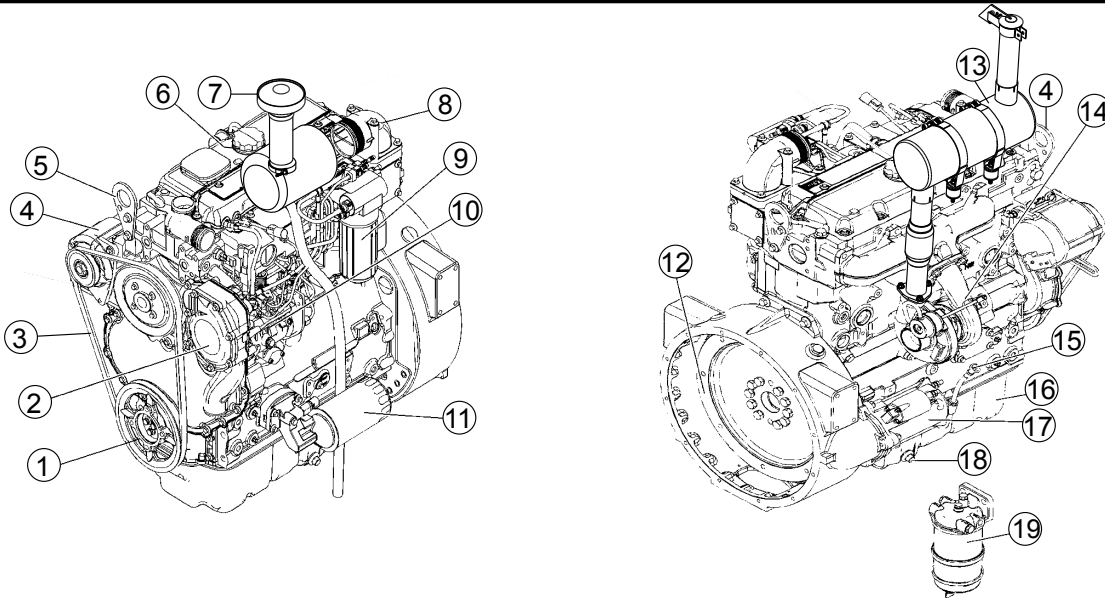

Figure 8. Perkins 1104D-44TA Diesel Engine Components

The engine (Figure 8) must be checked for proper lubrication and filled with fuel prior to operation. Refer to the manufacturer's engine manual for instructions and details of operation and servicing.

1. **Crankshaft Pulley** — Check fan V-belt between V-Pulley and alternator to determine proper belt tension.
2. **Water Pump** — Circulates coolant flow through engine block.
3. **V-Belt** — Driven by the engine crankshaft during operation, drives the water pump/fan as well as the alternator.
4. **Alternator** — Provides power to the electrical system. Replace with only manufacturer's recommended replacement parts.
5. **Front/Rear Lifting Eye** — When lifting of the engine is required attach a strap or chain of adequate lifting capacity to these lifting points.
6. **Oil Filler Port/Cap** — Remove this cap to add engine oil to the crankcase. Fill with recommended type of oil as specified in the maintenance section of this manual
7. **Air Cleaner** — Prevents dirt and other debris from entering the fuel system. Remove clamps on air filter canister to gain access to filter element. Replace with only manufacturer's recommended type air cleaner.
8. **Air Intake Port** — Attach the air filter hose to this port.
9. **Secondary Fuel Filter** — Prevents dirt and other debris from entering the fuel system. Service the fuel filter as recommended in the maintenance section of this manual.
10. **Fuel Injection Pump** — Provides equal fuel flow to injectors.
11. **Oil Filter** — Spin-on type, filters oil for contaminants.
12. **Flywheel** — A rotating gear attached to a driveshaft.
13. **Muffler** — Used to reduce noise and emissions. **DO NOT** touch muffler when engine is running. Allow muffler to cool before performing maintenance.
14. **Turbocharger** — Provides pressurized intake air to the cylinder by means of a turbine energized by exhaust gas that rotates the blower.
15. **Dip Stick** — Remove dipstick to determine if the engine oil level is low. If low, add oil as specified in Table 4.
16. **Oil Pan** — Reservoir for engine oil. Capacity is 2.08 gallons (2.5 liters).
17. **Starter/Solenoid** — This engine uses a 12VDC, 2.7kW (3.7 HP) starter motor with solenoid.
18. **Oil Drain Plug (2)** — Remove to drain crankcase oil. Always dispose of used oil and oil filters in an environmentally safe manner. **DO NOT** allow used oil to drain onto the ground or into a water runoff drain.
19. **Primary Fuel Filter** — Prevents dirt and other debris from entering the fuel system. Service the fuel filter as recommended in the maintenance section of this manual.

WARNING



NEVER operate the pump in a confined area or enclosed area structure that does not provide ample free flow of air.

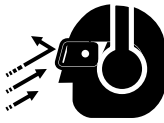

ALWAYS wear approved eye and hearing protection before operating the pump.



NEVER operate the pumps's engine with the engine hood removed. The possibility exists of hands, long hair, and clothing becoming entangled with the V-belt, causing injury and bodily harm.

NEVER place hands or feet inside the hopper. **ALWAYS** make while the engine is running. **ALWAYS** shut down the engine before performing any kind of maintenance service on the pump.

NOTICE

Reference Figures 5, 6, and 7 for the location of any control or component referenced in this section.

Before Starting

1. Read safety instructions at the beginning of manual.
2. Clean the entire pump, removing dirt and dust, particularly the engine cooling air inlet, and heat exchanger.
3. Check the air filter for dirt and dust. If air filter is dirty, replace air filter with a new one as required.
4. Check fastening nuts and bolts for tightness.



Fuel Safety

DANGER

Handle fuel safely. Motor fuels are highly flammable and can be dangerous if mishandled. **DO NOT** smoke while refueling. **DO NOT** attempt to refuel the pump if the engine is hot or running.

DANGER



Diesel fuel is extremely flammable, and its vapors can cause an explosion if ignited. **DO NOT** start the engine near spilled fuel or combustible fluids. **DO NOT** fill the fuel tank while the engine is running or hot.

DO NOT overfill tank, since spilled fuel could ignite if it comes into contact with hot engine parts or sparks from the ignition system. Store fuel in approved containers, in well-ventilated areas and away from sparks and flames. **NEVER** use fuel as a cleaning agent.

Fuel Check

1. Check the fuel gauge (Figure 9) built into the fuel tank cap to determine if the pump's engine fuel is low.

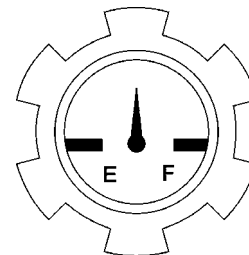

Figure 9. Fuel Cap Gauge

2. If fuel is low, remove fuel filler cap and fill with #2 diesel fuel (Figure 10).

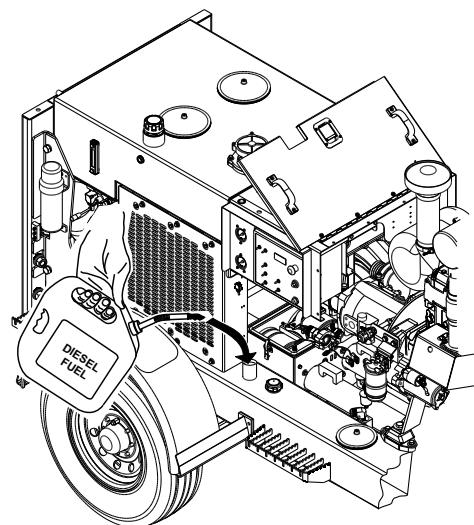

Figure 10. Adding Diesel Fuel

Engine Oil Check

1. Make sure pump/engine is placed on level ground.
2. Remove the engine oil dipstick from its holder (Figure 11).

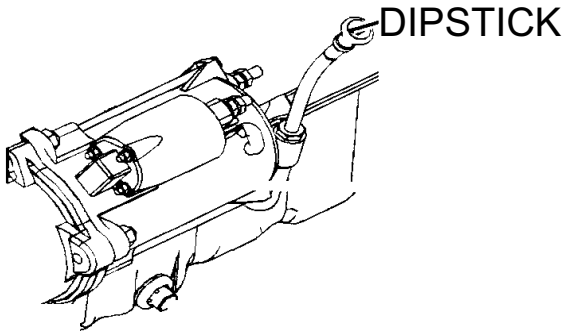

Figure 11. Engine Oil Dipstick Location

3. Verify that engine oil level (Figure 12) is maintained between the two notches on the dipstick.

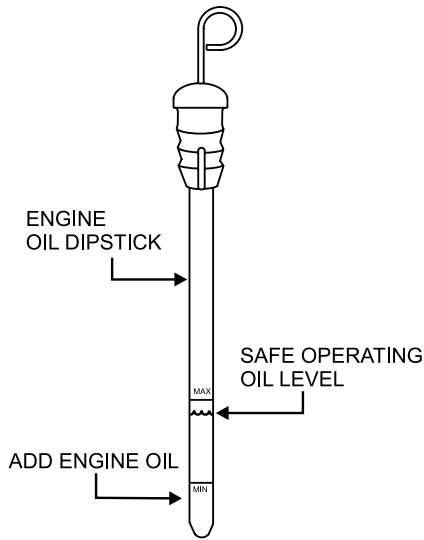
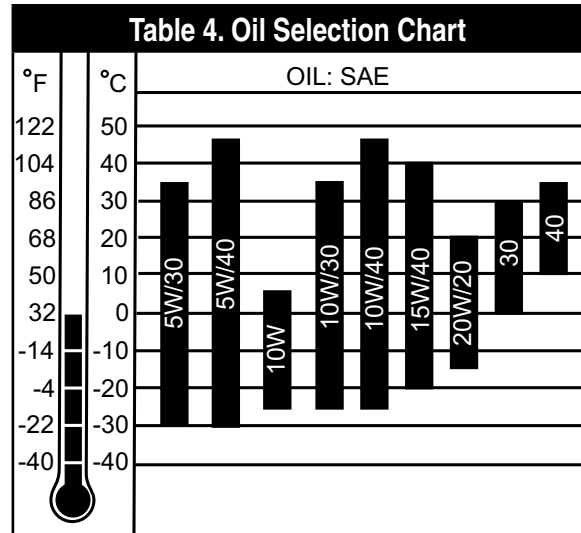

Figure 12. Engine Oil Level (Dipstick)

4. If the pump's engine oil is low, fill engine crankcase with lubricating oil through filler hole, but **DO NOT** overfill.
5. The oil listed in Table 4 is recommended to ensure better engine performance. Use class CD or higher grade motor oil.



Hydraulic Oil Check

1. Determine if the hydraulic oil level is low by observing the level of the oil in the **hydraulic oil sight glass** (Figure 13).

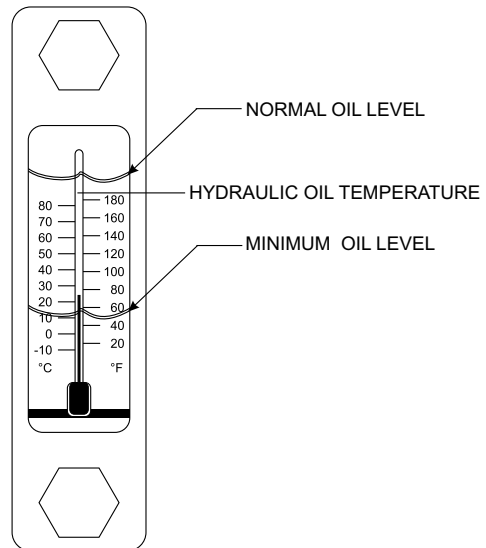

Figure 13. Hydraulic Oil Sight Glass

2. If the hydraulic oil level is low, remove the hydraulic oil tank cap just above the oil level sight glass (Figure 14) and add the correct amount of hydraulic oil to bring the hydraulic oil level to a normal safe operating level. Use Shell oil Tellus 68 or Mobil oil DFE26.

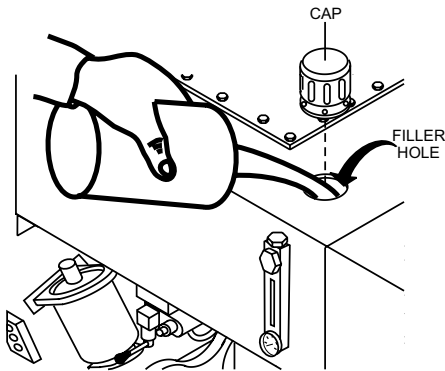

Figure 14. Adding Hydraulic Oil (Filler Hole)

3. Check the oil level in the **lubrication box** (Figure 15). If low, fill with up to 3 gallons of SAE #30 motor oil (Figure 14). The oil level must be checked daily. The lubrication box should be serviced as described in the maintenance section.

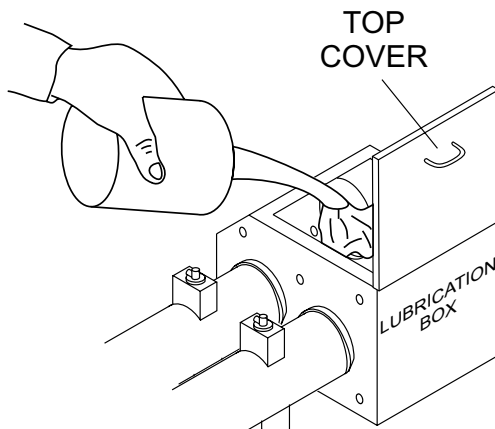

Figure 15. Filling the Lubrication Box

Location of Pump

1. Place the pump in the best location on the site to pump concrete efficiently.
2. Lay down the hose in the shortest distance possible.

Rear Stabilizer Jacks

WARNING

NEVER place feet under jack while operating.

ALWAYS retract rear stabilizer jacks prior to towing.

ALWAYS retract rear stabilizer jacks prior to servicing to relieve load (working pressure).

To reduce excessive vibration and rocking of the pump, set the rear stabilizers as follows:

1. Locate both the left and right rear stabilizer jacks (Figure 16).

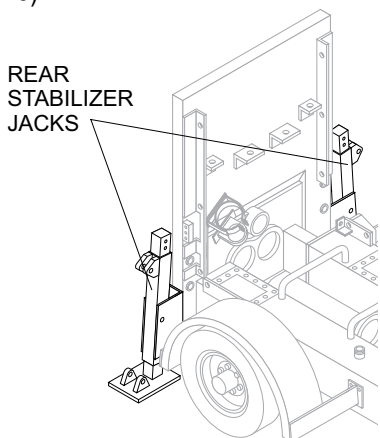

Figure 16. Locating Rear Stabilizer Jacks

2. Remove the cotter pin (Figure 17) from the handle tee bolt eye, and then pull the handle tee to release the stabilizer jack.

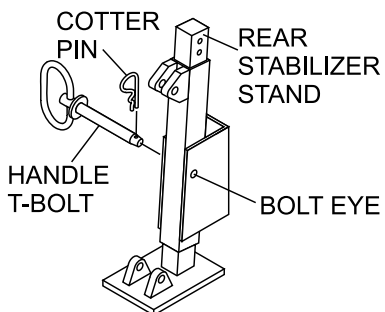
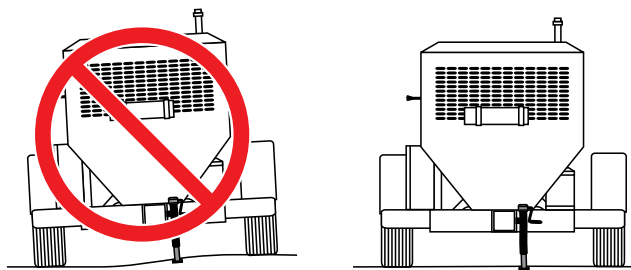

Figure 17. Rear Stabilizer Jack

3. Position both rear stabilizer jacks on firm (not loose) level ground (Figure 18).



INCORRECT

CORRECT

Figure 18. Rear Stabilizer Stand Deployment

4. Align the hole on the stabilizer jack with the hole on the frame body and insert handle tee bolt.
5. Insert the cotter pin into handle tee bolt eye to lock the stabilizer jack.

Hydraulic Rear Stabilizer Jacks (Optional)

If your pump comes equipped with hydraulic rear stabilizers (Figure 19), they can be controlled as follows:

1. Push down the middle control lever to extend the right hydraulic rear stabilizer.

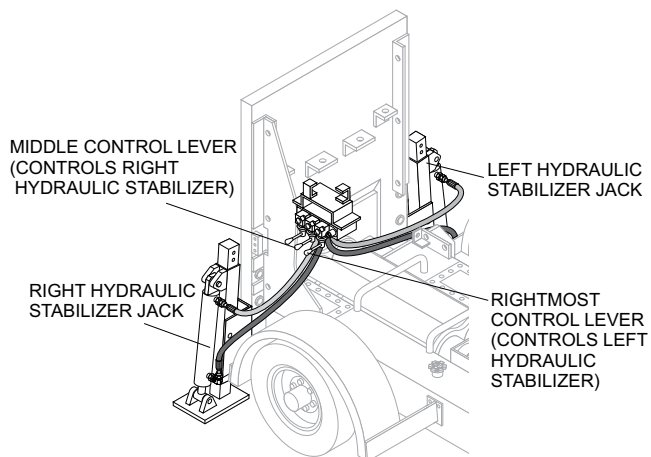

Figure 19. Control Levers for Hydraulic Rear Stabilizers

2. Push up the middle control lever to retract the right hydraulic rear stabilizer.
3. Push down the rightmost control lever to extend the left hydraulic rear stabilizer.
4. Push up the rightmost control lever to retract the left hydraulic rear stabilizer.

Starting Procedure

WARNING

DO NOT attempt to operate this concrete pump until the Safety, General Information and Inspection sections have been read and understood.

1. Locate the **emergency stop switch** (Figure 20) on the **digital control panel**. Turn the emergency stop switch clockwise and release (open). This will allow the engine to start.



Figure 20. Emergency Stop Switch

NOTICE

If the **emergency stop switch** is in the closed position (**STOP**), engine will not start. To start the engine, make sure the emergency stop switch is in the **OPEN** position (fully extended).

2. Place the **cylinder stroke control switch** in the **AUTOMATIC** position (Figure 21).

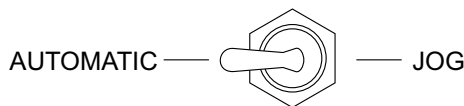

Figure 21. Cylinder Stroke Control Switch (Automatic)

3. Place the **pumping control switch** in the **CENTER OFF** position (Figure 22) for normal pumping operation.

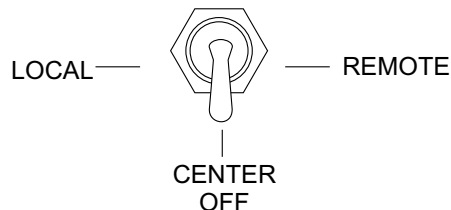

Figure 22. Pumping Control Switch (OFF)

4. Place the **direction control switch** to the **FORWARD** position (Figure 23).

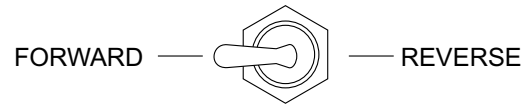

Figure 23. Direction Control Switch (FORWARD)

5. To start the engine, insert the ignition key (Figure 24) into the ignition switch and turn the key to the **ON** position.

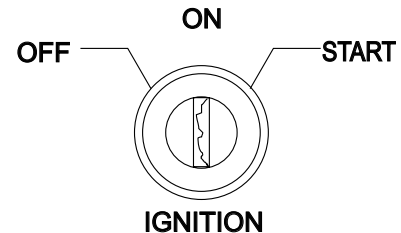

Figure 24. Ignition Switch

6. When the ignition key is in the **ON** position, the **digital readout screen** (primary) will cycle through 3 displays as shown in Figure 25.

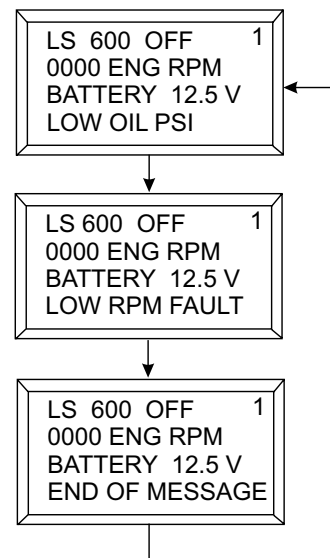

Figure 25. Primary Screen (Ignition Key ON)

7. Turn the key to the **START** position and listen for the engine to start. In warm weather let engine warm up for 5 minutes. In cold weather, let engine warm up for 10 minutes.

Hose Lubrication

Before pumping, it is necessary to lubricate the hose.

This procedure prevents separation and blockages in the hose. Inspect the lines at all times to prevent problems.

Before concrete is discharged into the hopper, it is suggested that 3 to 4 gallons of water be sprayed into the hopper, followed by approximately 5 gallons of a creamy cement and water slurry (1/2 bag of cement to 5 gallons of water).

NOTICE

Getting the concrete to flow through the hose at the start of the pumping cycle can be one of the most critical operations of the pour.

Priming The Pump With Slurry Mixture

It is **CRITICAL** to the successful operation of a concrete pump that the manifold and all delivery hoses, pipes and elbows are coated with a film of lubrication **BEFORE** you attempt to pump concrete.

Failure to properly prepare the pump and system will result in a “dry pack” of concrete, blocking the shuttle valve tube or delivery line.

1. Connect the entire delivery system to the pump. Pour 5 gallons of water and a bag of raw cement into the hopper.
2. Place the **direction control switch** to the **REVERSE** position (Figure 26). This will mix the water and cement into slurry.

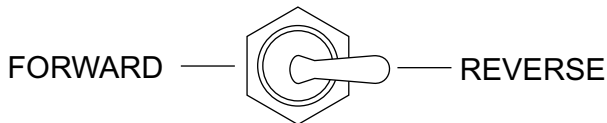

Figure 26. Direction Control Switch (REVERSE)

3. Mix the slurry to the consistency of a smooth batter.
4. Position the first ready-mix truck at the hopper. Check the concrete. **DO NOT** discharge concrete into hopper at this time.

5. Place the **direction control switch** in the **FORWARD** position. This will start the flow of the slurry to the hoses.
6. Keep the slurry flowing until most of it is pumped out. However, make sure that some slurry is left on the hopper when concrete is first discharged from the ready-mix truck.

Pumping

WARNING

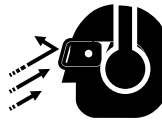

Safety glasses and hearing protection **MUST** be worn at all times when operating the pump. Failure to follow safety guidelines can result in serious injury.

NOTICE

A well-planned location of the pump and routing of the hose before starting a pour may save subsequent moves throughout the job.

1. Place the **pumping control switch** in the **LOCAL** position (Figure 27) for normal pumping operation.

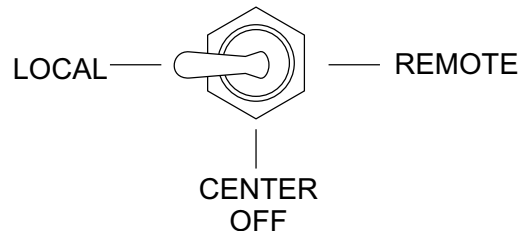

Figure 27. Pumping Control Switch (Local)

2. Holding the **volume control switch** (Figure 28) to the right will increase pumping volume to approximately 10 strokes per minute. Holding the volume control switch to the left will decrease pumping volume.

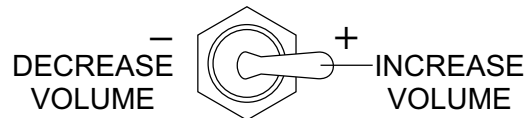

Figure 28. Volume Control Switch

3. A thumping sound (cylinder stroke) should be heard. The thumping sound represents the number of strokes per minute (volume) of the pump.

OPERATION

4. Scroll through the **digital readout screen** with the scroll switch to go to screen 7 (Figure 29). This screen will show the volume in strokes per minute.

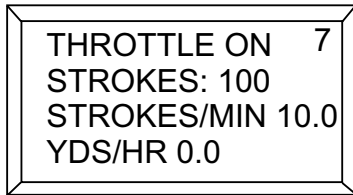

Figure 29. Strokes Per Minute Display

5. Let the pump cycle until the hydraulic oil temperature (Figure 30) is approximately 50° to 60° F.

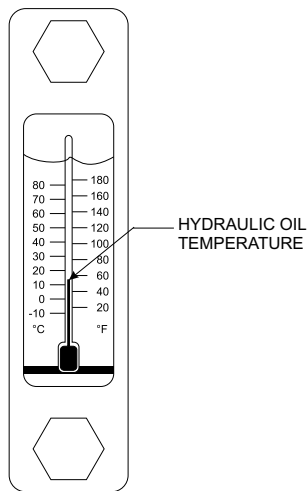
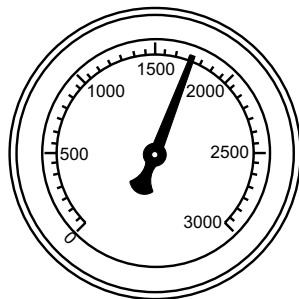

Figure 30. Hydraulic Oil Temperature Gauge

6. The **accumulator pressure gauge** (Figure 31) should read approximately 1750 pounds per square inch (psi).



ACCUMULATOR
PRESSURE

Figure 31. Accumulator Pressure Gauge

7. Push the **hopper remixer control lever** downward (Figure 32). The hopper remixer control lever is located to the left of the hydraulic temperature gauge.

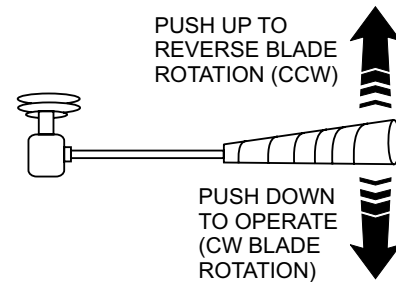

Figure 32. Hopper Remixer Control Lever

8. Observe that the blades (Figure 33) inside the hopper are rotating in a clockwise direction (forward). To make the blades rotate in a counterclockwise direction (reverse), push the hopper remixer control lever **upward** (Figure 32).

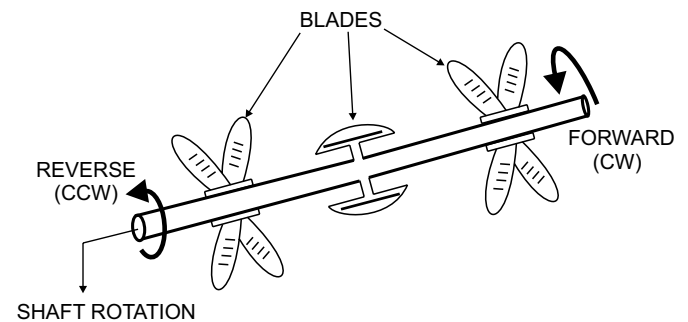

Figure 33. Hopper Remixer Blade (Rotation)

9. Place the volume control switch (Figure 27) in the increase volume position (right) to increase the volume to 25-30 strokes per minute. Slowly discharge the concrete from the ready-mix truck into the hopper and completely fill it. Keep the pump running continuously until concrete is discharging at the end of the delivery system. If the pump is stopped during this procedure, a blockage may occur.

CAUTION

HOSE/LINE BLOCKAGE

If hoses or lines are blocked for any reason, or if the lines are kinked when starting up or during the pumping cycle, the pump pressure could straighten out the kink or force out the blockage. This rapid surge of material could cause the lines to whip or move in a manner that could cause injury to personnel.

10. It is important that once the slurry procedure is completed, and concrete is flowing through the hose, **DO NOT** stop the pour until all the slurry is pumped out and the concrete has reached the end of the hose. The only time to stop the pump during the priming procedure is if a blockage occurs.
11. If it is necessary to replace or add a section of delivery system, after the initial lubrication procedure, wet the inside area of the hose, pipe or elbow with 5 gallons of water per 25 foot length, before adding it to the system.

NOTICE

When pumping long distance or pumping stiff mixes, you can expect a drop in volume compared to shorter lines and wetter mixes due to the change in valve efficiency or cavitation.

Remote Control (Optional)

The LS600P Concrete Pump has a remote control feature that allows the pump to be remotely controlled. If desired, the pump can be operated via a receiver/transmitter (radio) or a hardwire method, which utilizes a 25-ft. extension cable. Contact MQ Sales Department to order remote control.

Radio Remote Control

Installation of the Radio Remote Control Assembly

1. Remove the two screws (Figure 34) on the **digital control panel** that secure the front panel to the control box.

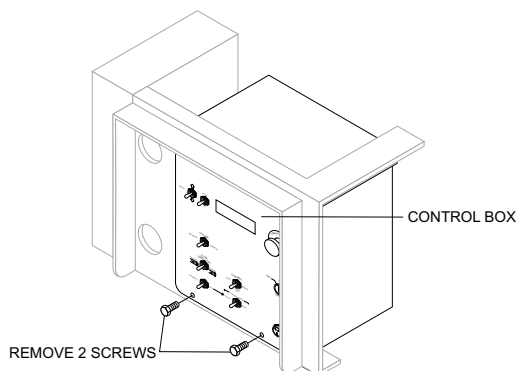

Figure 34. Removing The Control Box

2. Tilt and slowly pull out the control panel and place on top (Figure 35) of control box to gain access inside the box.

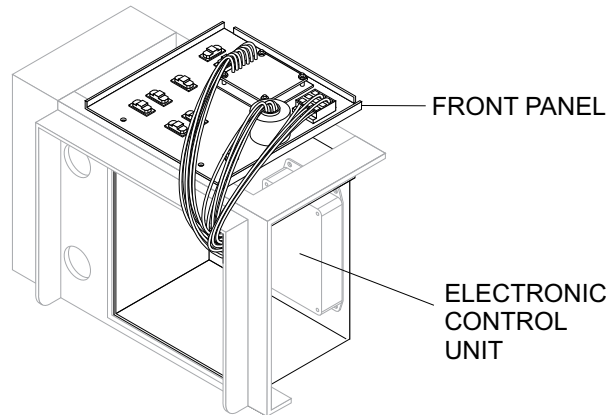

Figure 35. Pulling Out Control Panel

3. Install the wireless remote module (Figure 36) with the 2 screws and nuts provided inside the control panel. Connect the 3-wire connector from the wireless remote module to the electronic control unit.

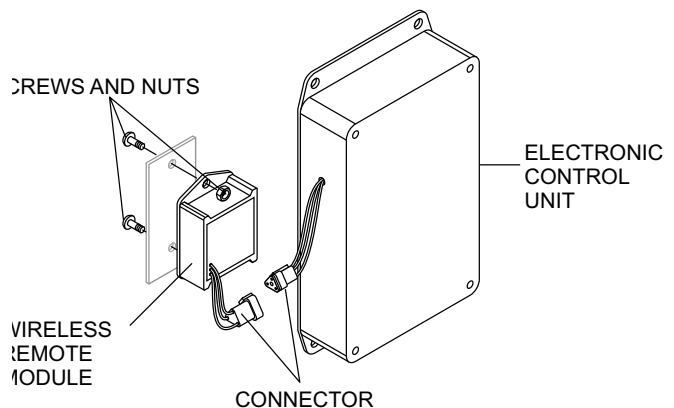

Figure 36. Installing Remote Control Module

- Reinstall the control panel and tighten the 2 retaining screws.
- On the top of the unit, to the right of the control box (Figure 37), hammer out the knock-out hole and install the remote antenna.

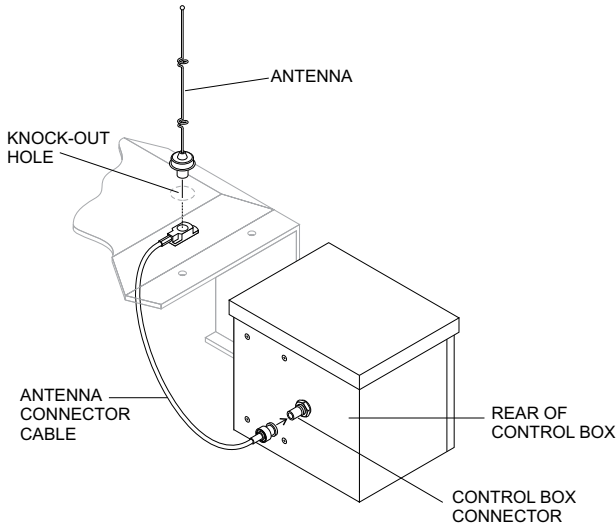

Figure 37. Antenna Installation

- Connect the antenna cable to the connector on the rear (Figure 37) of the control box.

Radio Remote Control Buttons Operation

Before the remote control hand-held module can be used, the **pumping control switch** on the control box must be placed in the **REMOTE** position (Figure 38).

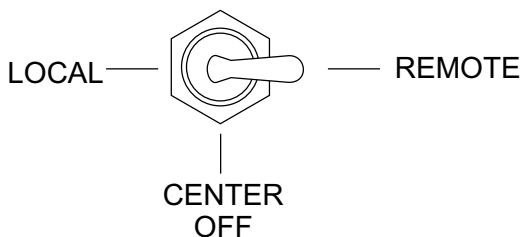

Figure 38. Pumping Control Switch (Remote)

Remote pumping operation can be performed by the hand-held radio remote control (Figure 39).

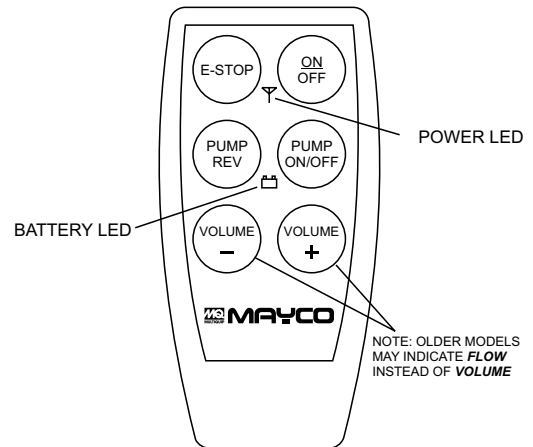

Figure 39. Radio Remote Control

The buttons on the hand-held remote control module have the following functions:

- **ON/OFF** – Turns the power on or off. When power is on the power LED lights red. If the battery LED turns red, 9V battery needs to be replaced.
- **E-STOP** – Turns off the pump completely in an emergency.
- **PUMP ON/OFF** – Starts and stops the forward pumping.
- **PUMP REV** – momentarily pumps in reverse direction.
- **VOLUME (+)** – used to increase the pumping volume.
- **VOLUME (-)** – used to decrease the pumping volume.

Radio Remote Control Programming

Before starting operation of the hand-held *radio remote control*, go to Screen 9 of the *digital readout screen*:

Screen 9

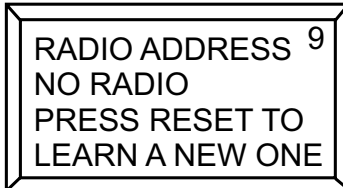

1. Press the **ON/OFF** button on the radio (wireless) remote control to turn on the power. Hold down the **RESET** switch. The display will now show.

Screen 9



2. After 5 seconds, the display will show:

Screen 9



3. The hand-held remote control module is now ready for use.

Remote Control Cable Operation (25 ft.)

The remote control cable (Figure 40) has the following controls:

- **Pump ON/OFF** – Starts and stops the forward pumping.
- **Pump REV** – Starts pumping in reverse direction.

Connect the *remote control cable* (Figure 40) to the receptacle labeled *remote* located on front of the digital panel.

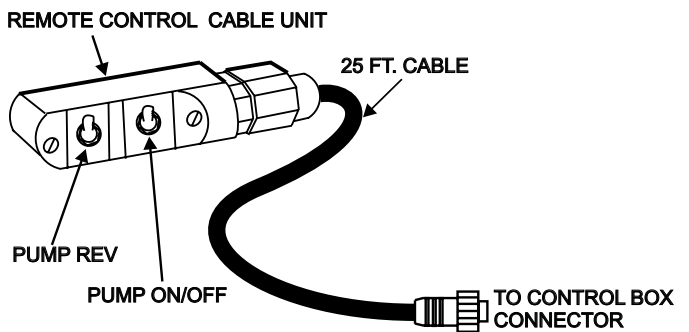

Figure 40. Remote Control Cable

Before the remote control cable can be used the pumping volume rate must be set.

1. Start the pump as outlined in the pumping section of this manual.
2. Place the *pumping control switch* in the **LOCAL** position.
3. Using the momentary volume control switch, adjust the pumping rate (volume) to the desired strokes per minute.
4. Once the desired pumping rate has been achieved, place the *pumping control switch* in the **REMOTE** position.

MAINTENANCE

Table 5. Inspection/Maintenance		10 Hrs DAILY	250 Hrs	500 Hrs	1000 Hrs	OTHER
Engine	Check Engine Fluid Levels	X				
	Check Air Cleaner	X				
	Check Battery Acid Level	X				
	Check Fan Belt Condition	X				
	Check for Leaks	X				
	Check for Loosening of Parts	X				
	Replace Engine Oil and Filter ¹		X			
	Clean Air Filter		X			
	Check Fuel Filter/Water Separator Bowl	X				
	Clean Unit, Inside and Outside	X				
	Change Fuel Filter			X		
	Clean Radiator and Check Coolant Protection Level ²			X		
	Replace Air Filter Element ³			X		
	Check all Hoses and Clamps ⁴				X	
	Clean Inside of Fuel Tank				X	
	Check Battery		X			
	Visually Check for Oil Leaks	X				
Pump	Hydraulic Oil Level	X				
	Lubrication Box	X				
	Replace Hydraulic Oil				X	
	Clean Hydraulic Filters					
	Grease Shuttle Axle Crank	X				2 Hrs.
	Grease Shuttle Cylinder					Monthly
	Check System Pressure	X				
	Check Hardware for Tightness					Weekly
	Check Cutting Wear Ring					Weekly
Trailer	Check Brake Lights	X				
	Check Tire Conditions	X				
	Inspect Safety Devices / Decals	X				
	Check Wheel Bearings					6-Months
	Inspect Brake Lining					6-Months

*1 Replace engine oil and filter at 100 hours, first time only.

*2 Add "Supplemental Coolant Additives (SCA'S)" to recharge the engine coolant.

*3 Replace primary air filter element when restriction indicator shows a vacuum of 625 mm (25 in. H20).

*4 If blowby hose needs to be replaced, ensure that the slope of the blowby hose is at least a 1/2 inch per foot, with no sags or dips that could collect moisture and/or oil.

GENERAL INSPECTION

Prior to each use, the pump should be cleaned and inspected for deficiencies. Check for loose, missing or damaged nuts, bolts or other fasteners. Also check for fuel, oil, and coolant leaks. Use Table 5 as a general maintenance guideline **Engine Side** (Refer to the Engine Instruction Manual)

CAUTION

Certain maintenance operations or machine adjustments require specialized knowledge and skill. Attempting to perform maintenance operations or adjustments without the proper knowledge, skills or training could result in equipment damage or injury to personnel. If in doubt, consult your dealer.

WARNING



Accidental starts can cause severe injury or death.

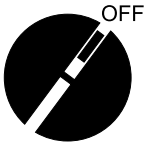

ALWAYS place the ON/OFF switch in the OFF position.



Disconnect and ground spark plug leads and disconnect negative battery cable from battery before servicing.

WARNING



Some maintenance operations may require the engine to be run. Ensure that the maintenance area is well ventilated. Exhaust contains poisonous carbon monoxide gas that can cause unconsciousness and may result in **DEATH**

CAUTION



ALWAYS allow the engine to cool before servicing. **NEVER** attempt any maintenance work on a hot engine.

Air Cleaner with Dust Indicator

NOTICE

The air filter should not be changed until the indicator reads **“RED”**. Dispose of old air filter. It may not be cleaned or reused.

This indicator (Figure 41) is attached to the air cleaner. When the air cleaner element is clogged, air intake restriction becomes greater and the dust indicator signal shows **RED** meaning the element needs changing or service. After changing the air element, press the dust indicator button to reset the indicator.

PUSH CENTER TO RESET

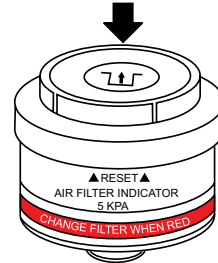



Figure 41. Air Cleaner Service Indicator

Air Cleaner (250 Hours)

This Perkins diesel engine is equipped with a replaceable, high-density paper air cleaner element (Figure 42). This air cleaner may have an *inner* element (option) that is used as a backup filter should the *main* element becomes damaged.

CAUTION



Wear protective equipment such as approved safety glasses or face shields and dust masks or respirators when cleaning air filters with compressed air.

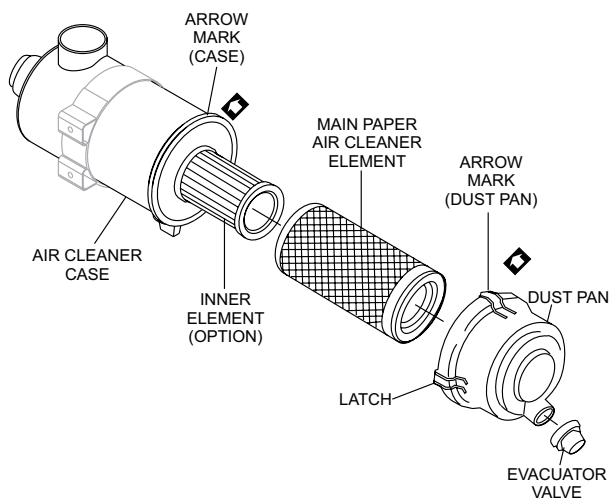

Figure 42. Air Cleaner

1. Release the latches located on either side of the air cleaner dust pan, and remove the dust pan.
2. Remove the air cleaner element.
3. Check the air cleaner daily or before starting the engine
4. Check for and correct heavy buildup of dirt and debris along with loose or damaged components.

NOTICE

Operating the engine with loose or damaged air cleaner components could allow unfiltered air into the engine causing premature wear and failure.

5. To clean the main element (paper air filter) as referenced in (Figure 43), tap the filter element several times on a hard surface to remove dirt, or blow compressed air (not to exceed 30 psi (207 kPa, 2.1 kgf/cm²) through the filter element from the inside out.

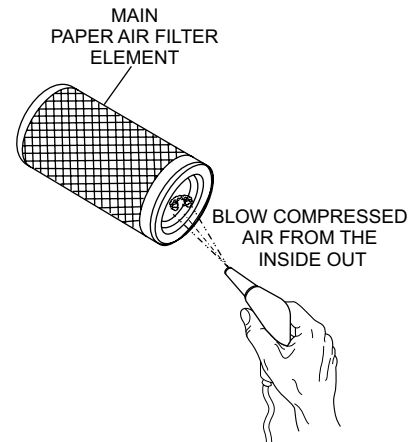

Figure 43. Cleaning Paper Air Filter Element

NOTICE

DO NOT use excessive air pressure or the paper air filter element will be damaged and will need to be replaced.

6. Replace the element if it is damaged or excessively dirty.
7. Clean the inside of the dust pan.
8. Reinstall the element or if equipped, the precleaner over the paper air cleaner element.
9. Reinstall the air cleaner dust pan and secure the latches.

NOTICE

DO NOT run the engine with the air cleaner removed or without an element.

Checking Engine Oil (Daily)

1. When checking or adding oil, place the machine so the engine is level.
2. Pull the engine oil dipstick from its holder.
3. Determine if engine oil is low. Oil level should be between the upper and lower limit (Figure 44) on the dipstick.

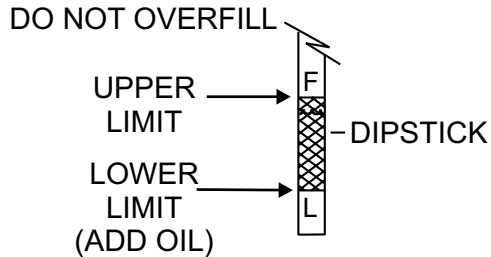

Figure 44. Dipstick Engine Oil Level

4. If oil level is low, add correct amount of engine oil to bring oil level to a normal safe level (See Recommended Viscosity Grades, Table 6).
5. Allow enough time for any added oil to make its way to the oil pan before rechecking.

Table 6. Oil Selection Chart		OIL: SAE	
°F	°C		
122	50		
104	40		
86	30	5W/30	5W/40
68	20	10W	10W/30
50	10		10W/40
32	0		15W/40
-14	-10		20W/20
-4	-20		30
-22	-30		40
-40	-40		

Changing Engine Oil And Filter

Change the engine oil and filter after the first 50 hours of use, then every 6 months or 250 hours. Refer to Table 6 for recommended oil viscosity.

1. Prepare a waste oil collector to drain the oil into.
2. Remove the oil filler cap while draining the oil to allow the engine to drain easily.

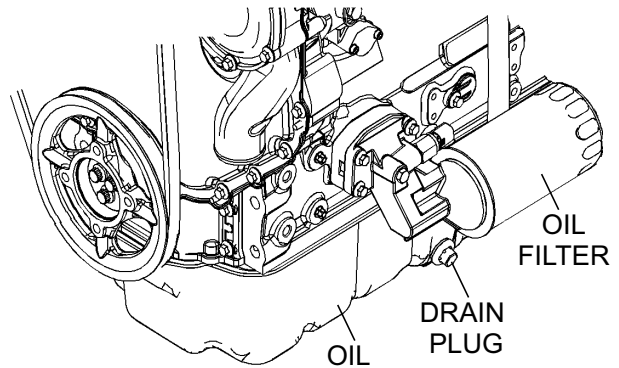

Figure 45. Oil Service Components

3. Remove the drain plug (Figure 45) to drain the oil.
4. After oil is sufficiently drained, securely tighten the drain plug.
5. Using a filter wrench, turn the oil filter counterclockwise to remove.
6. Clean sealing surface on engine where filter mounts.
7. Coat the seal of the new oil filter with clean engine oil. Install new filter first by hand until it contacts the engine sealing surface. Tighten it another 3/4 turn using the filter wrench.
8. Fill engine crankcase with high quality detergent oil classified "For Service CF, or CF-4". Fill to the upper limit of dipstick. **DO NOT** overfill. Crankcase oil capacity with oil filter replacement is 1.5 gals (7 liters).
9. Run the engine briefly for several minutes. Watch for oil leakage. Shut the engine down and allow it to sit for several minutes. Top off the oil to the upper limit on the dipstick.

- Be sure to coat the seal (Figure 46) of the new oil filter with clean engine oil.

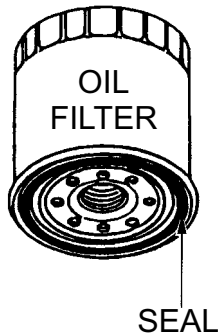



Figure 46. Oil Filter/Seal

Radiator/Cooling System

COOLANT (ANTIFREEZE/SUMMER COOLANT/WATER)

PERKINS recommends antifreeze/summer coolant for use in their engines, which can be purchased in concentrate (and mixed with 50% demineralized water) or pre-diluted. See the PERKINS Engine Owner's Manual for further details.

WARNING



If adding coolant/antifreeze mix to the radiator, **DO NOT** remove the radiator cap until the unit has completely cooled. The possibility of **hot!** coolant exists which can cause severe burns.

Day-to-day addition of coolant is done via the radiator. When adding coolant to the radiator, **DO NOT** remove the radiator cap until the unit has completely cooled. Coolant capacity is 4.5 gallons (17 liters).

Operation in Freezing Weather

When operating in freezing weather, be certain the proper amount of antifreeze Table 7 has been added.

Vol % Anti-Freeze	Freezing Point		Boiling Point	
	°C	°F	°C	°F
50	-37	-34	108	226

Radiator Maintenance

- Check radiator for leaks that would indicate corrosion or damage.
- Check coolant level daily. Top off as necessary. Always use recommended coolant/antifreeze. Use the mixing ratios specified by the coolant/antifreeze manufacturer or (Table 7). Replace coolant/antifreeze at least once a year.
- Check radiator hoses for fatigue or cracking. Replace any defective hoses immediately.
- Check radiator cap seal and replace as necessary.
- Blow off dirt and dust from fins and radiator with 28 psi (193 kPa) or less of compressed air (Table 7). Be careful not to damage the fins with the compressed air.

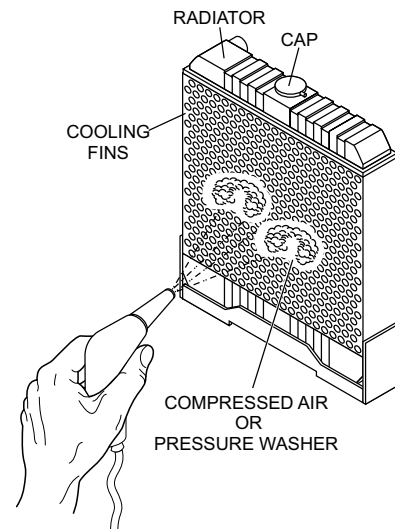

Figure 47. Radiator Cleaning

NOTICE

NEVER use high-pressure water or compressed air at greater than 28 psi (193 kPa) or a wire brush to clean the radiator fins. Radiator fins damage easily.

- If there is a large amount of contamination on the fins, use detergent to clean and rinse thoroughly with tap water.

Fuel Filter

Replace the secondary fuel filter (Figure 48) every 800 hours. Refer to your engine manual for specific details to perform this operation.

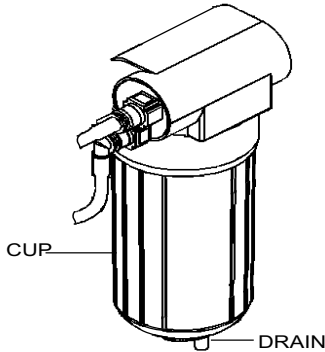

Figure 48. Fuel Filter

Fuel/Water Separator Primary Filter

1. Inspect the fuel filter water separator daily. If the fuel filter/water separator (Figure 49) has collected a significant amount of water and sediment at the bottom of the cup, it should be drained off.

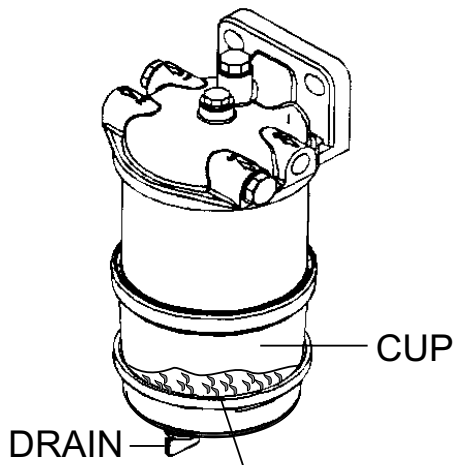

Figure 49. Fuel Water Separator

2. To remove water and sediment from the cup, place any fuel valves to the **OFF** position and unscrew the cup from the base.
3. Pour the contents of the cup into a safety container. Rinse cup with a mild detergent and reattach cup to base.
4. Return fuel valves to the **ON** position.

In-Line Fuel Filter

Replace the engine in-line fuel filter (Figure 50) every year or 300 hours.

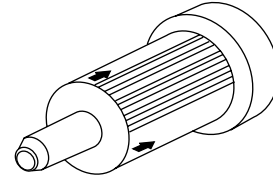

Figure 50. In-Line Fuel Filter

Oil And Fuel Lines

1. Check the oil and fuel lines and connections regularly for leaks or damage. Repair or replace as necessary.
2. Replace the oil and fuel lines every two years to maintain the line's performance and flexibility.

V-BELT

Visually examine the V-belt (Figure 51) and determine if it is full of tiny cracks, frayed, has pieces of rubber missing, is peeling or otherwise damaged.

Also, examine the belt and determine if it is **oil soaked** or "**glazed**" (hard shiny appearance on the sides of the belt). Either of these two conditions can cause the belt to run hot, which can weaken it and increase the danger of it breaking.

If the V-belt exhibits any of the above wear conditions replace the V-belt immediately.

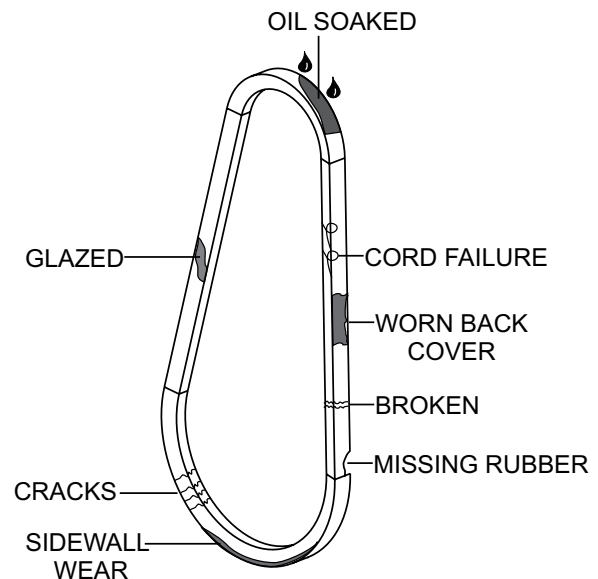



Figure 51. Drive Belt Inspection

Battery Maintenance

⚠ **DANGER**

Use all safety precautions specified by the battery manufacturer when working with the battery.



Flammable, explosive gas. (produces hydrogen gas while charging or during operation). Keep area around battery well ventilated and keep from any fire source.



Battery electrolyte contains corrosive, toxic chemical. (dilute sulfuric acid). Avoid contact with eyes and skin.



Shock or Fire due to electric short-circuit. Disconnect battery cables before inspecting electrical system and never "spark" battery terminals to test for charge.





Mishandling of the battery shortens the service life of the battery and adds to maintenance cost. When handling the battery do the following:

- Be careful not to let the battery electrolyte come in contact with your body or clothing.
- **ALWAYS** wear eye protection and rubber gloves, since the battery contains sulfuric acid which burns skin and eats through clothing.

⚠ **CAUTION**

Battery Safety

Wear safety glasses or face mask, protective clothes, and rubber gloves when working with battery.

- **ALWAYS** check the battery terminals periodically to ensure that they are in good condition.
- Use wire brush or sand paper to clean the battery terminals.
- **ALWAYS** check battery for cracks or any other damage. If white pattern appears inside the battery or paste has accumulated at the bottom, replace the battery.
- **NEVER** attempt to charge a battery that is frozen. The battery can explode unless first allowed to thaw.

- If the pump will not be in operation for a long period of time, store in cool dry place and check the battery charge level every month to maintain the performance of the battery.
- Check the battery regularly and make sure that each electrolyte level is to the bottom of the vent well (Figure 52). If necessary add only distilled water in a well-ventilated area. Never operate or recharge without sufficient fluid in the battery.

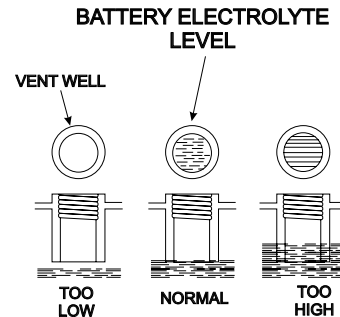
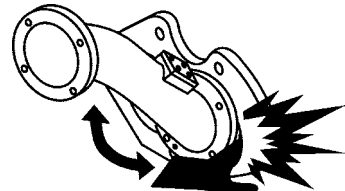

Figure 52. Battery Electrolyte Levels

Cleaning The Pump And Delivery System

⚠ **DANGER**

AMPUTATION HAZARD



During routine maintenance or removing material blockage, you will be required to put your hand in the concrete cylinders or near the shuttle tube. You are at **extreme risk** of injury or **AMPUTATION** if the engine is running or if pressure is in the hydraulic system.

Prior to performing any maintenance on the pump, follow described lock out-tag out procedures. Stop the engine by turning off the ignition switch and remove the starter key.

Place a **DO NOT OPERATE** tag over the switch and disconnect the battery. The pressure reading on the accumulator pressure gauge **MUST** read **zero**. **ALWAYS** make sure the accumulator circuit pressure reads zero prior to performing any maintenance on the pump

Cleaning the pump is a very important operation as it determines how the machine will pump the next time it is used.

NOTICE

NEVER use muriatic acid to clean the pump. Acid will dissolve the chrome finish on material cylinder bore and main hydraulic cylinder rods.

At the end of every pour, or because of long delays during a pour, the pump and delivery system must be thoroughly cleaned by removing all concrete material.

1. Following the **clearing concrete blockage** operating procedure, ensure that there is no blockage in the hose and line or in the shuttle tube. If a blockage exists, clear it.
2. Pump concrete until the opening of the concrete cylinder intake in the hopper is visible.
3. Stop the pump.
4. Carefully disconnect the first hose joint at the shuttle tube discharge elbow.
5. Add water to the hopper. Pump and flush clean the entire hopper, shuttle tube and discharge elbow with water.
6. Scoop out 12 inches of concrete from the inboard end of the delivery hose. "Cork screw" a 6" x 6" x 8" sponge into the end of the first hose section. Reconnect the hose to the discharge elbow.
7. Fill hopper with water. Pump until sponge and clean water come out the discharge end of the hose and line system.
8. When the pump has been used to pump aggregate concrete or mixes with high fines content (60% or more sand) there will be a tendency for hardened concrete to build up on the inside surface of the shuttle tube. Therefore, at the end of every such pour, after the pump and system have been cleaned and the engine shut off, remove all remaining concrete.
9. Use only a 2½" diameter clean-out hook when back-pumping into redi-mix truck. Use a safety chain to secure the clean-out hook to some solid part of the mixer truck to prevent hook from jumping off of the drum. Run the pump at 6 strokes per minute maximum speed.

Hydraulic Oil System Maintenance

This Mayco pump is equipped with an in-tank return hydraulic filter with a 10 micron cleanable filter. The element has been designed to remove all particles large enough to cause wear and job break down. Under normal conditions, we recommend replacement every 6 months.

The most important factor to keep in mind is the effect of cold weather on the hydraulic oil. The viscosity (thickness) of the hydraulic oil will be much heavier.

ALWAYS run machine until oil temperature reaches a minimum of 50°F. before pumping. Damage to the main piston pump will occur if the machine is cycled too fast before the oil temperature reaches the minimum of 50°F. Cycle the machine at 6-8 strokes per minute at approximately 1/3 throttle.

In areas where the weather normally remains under 50°F., use Shell Oil Tellus 46 (or the equivalent). The above steps must be followed or severe damage to the main axial piston pump can occur.

1. When changing the hydraulic oil or topping off the reservoir (capacity 50 gal/189 liters), use only the following type hydraulic oil:

- Shell Oil Tellus 68
- Mobil DFE 26
- Texaco Rand HDC

NOTICE

DO NOT mix oil brands! This may impair quality.

2. The following components should be greased daily, hourly if necessary:

- Main Hydraulic Cylinders (2 grease fittings)
- Swing Axle Bushing (1 grease fitting)
- Shuttle Cylinder (2 grease fittings top and bottom)
- Discharge Nipple (3 grease fittings)
- Outriggers Option (2 grease fittings)

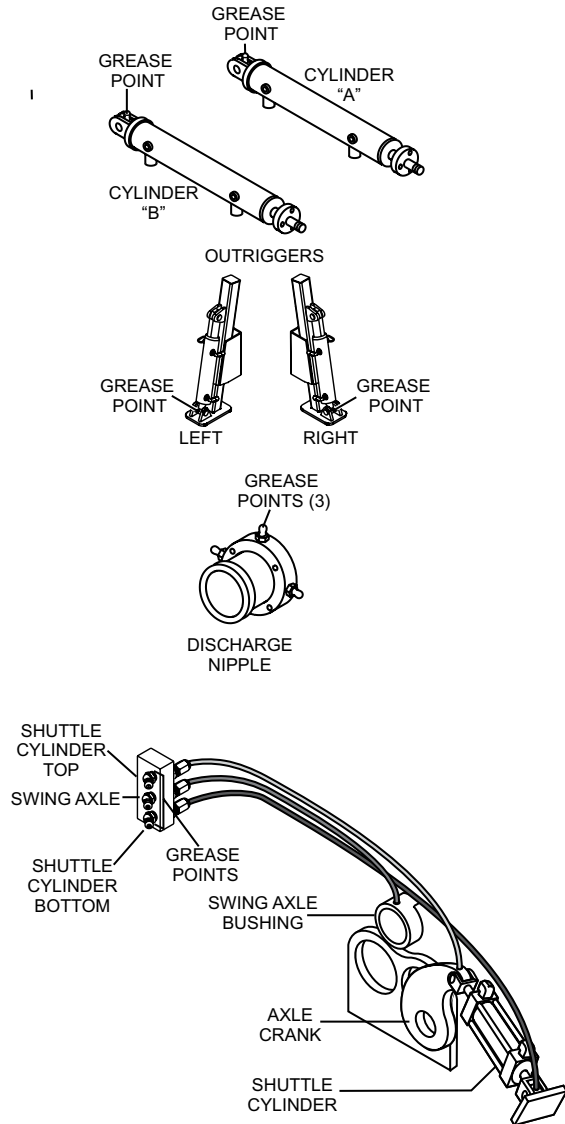

Figure 53. Lubrication Points

NOTICE

When lubricating the above components, use Lithium Based EP, Texaco Multitak 20 or Lubriplate ED-2 type grease.

Cylinder Lubrication Box

NOTICE

When using the pump during freezing conditions, completely drain the lubrication box and cover the hopper after pumping. Frozen liquid will restrict the piston travel and cause severe damage to the pump.

WARNING

ALWAYS follow lock out-tag out procedures before checking lubrication level, Stop the engine and remove the engine starter key. The possibility exists of severe bodily harm when hands are placed inside.

1. The lubrication level should be checked everyday prior to pumping and maintained at a height of 5 inches or about $\frac{1}{2}$ the concrete cylinder height. We recommend using a 30-weight motor oil.
2. As the rubber piston cups naturally wear, fine cement particles will accumulate in the box. Once the concrete paste reaches a height of about $\frac{1}{2}$ inch from the bottom of the box, drain and clean the lubrication box.

Cleaning the Lubrication Box

1. Remove the top cover and the drain plug (Figure 54) located at the bottom of the box and fully drain the inside of the box.
2. Once the box is drained, start the engine and stroke the cylinder (keep hands out of box) ten to fifteen times.
3. While stroking, spray water inside of the box to thoroughly clean out all contamination (Figure 54).
4. When the box is clean replace drain plug, add new lubrication and install the top cover.

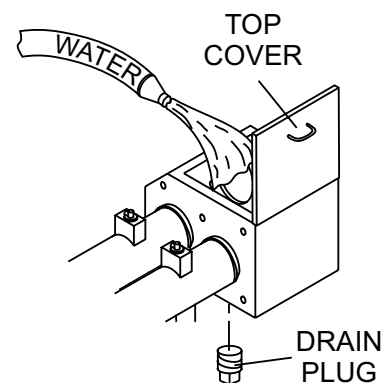
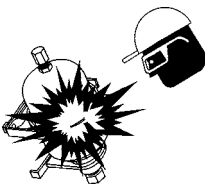

Figure 54. Cleaning the Lubrication Box

Accumulator Circuit

! DANGER



Improper accumulator charging can result in an explosion causing serious injury or death! Never use oxygen or compressed air to charge the accumulator! Only qualified personnel should perform this procedure. Use only dry nitrogen to charge the accumulator. Contact your Mayco service department or your local Hydac representative for proper charging procedure

The accumulator circuit has two functions in the hydraulic system.

- The accumulator circuit furnishes the hydraulic pressure to cycle the shuttle tube.
- The accumulator circuit also furnishes the pilot pressure necessary to activate the hydraulic system.

The accumulator circuit is equipped with a bladder type accumulator (Figure 55) charged with 1100 PSI of dry nitrogen. The accumulator stores one gallon of hydraulic oil, which is, under 1750 PSI of pressure.

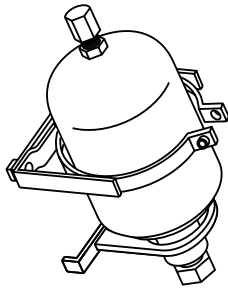

Figure 55. Accumulator

When the pump cycles, a part of the stored oil is released to the shuttle cylinder. This released oil pressure assures the shuttle tube has enough force to shear the cylinder of concrete passing from the concrete cylinder to the concrete delivery line during the cycle phase.

Checking Accumulator Bladder Pressure

The normal accumulator charge pressure should be approximately 1100 PSI. To check the accumulator pressure:

1. Start the engine and stroke the pump. The accumulator pressure gauge (Figure 30) should read 1750 PSI.
2. To determine the actual accumulator PSI, stop the engine and observe the pressure gauge. As the PSI reading slowly decreases, it will reach a point where there will be a sudden drop in the PSI. The PSI reading should be taken just prior to this sudden drop. If you do not read 1100 PSI, the accumulator may require charging or bladder replacement.

Wear Plate and Cutting Ring

Due to the abrasive nature of concrete, it is normal for the cutting ring to wear on its sides as it shears through the concrete inside the hopper. The metal-to-metal friction and the abrasiveness of the concrete will cause extreme wear and reduce sealing capability between the cutting ring and wear plate.

If the two components do not properly seat against each other, slurry will pump into the hopper rather than out the discharge line. See Figure 56. This condition can easily be observed.

1. The sudden change of the level of concrete inside the hopper during each pumping stroke
2. Concrete slurry squirting into the air from the hopper (Volcano effect)
3. When the output volume at the end of the delivery line decreases in pressure
4. Unusual frequent material packs in the Shuttle tube

It is important that the wear components be inspected weekly for proper sealing. Failure to inspect will eventually cause severe damage to the nun-plate and material cylinders. Visually inspect wear plate and cutting ring to ensure surfaces are sealed against each other.

If a deep groove or a wide space has developed on the sealing surfaces, it is time for replacement. Due to the motion of the **shuttle tube**, the cutting ring experiences a quicker rate of wear as opposed to the wear plate. The wear ring typically requires replacement two times per wear plate (2 to 1). When replacing the wear ring, also replace the rubber energizer ring.

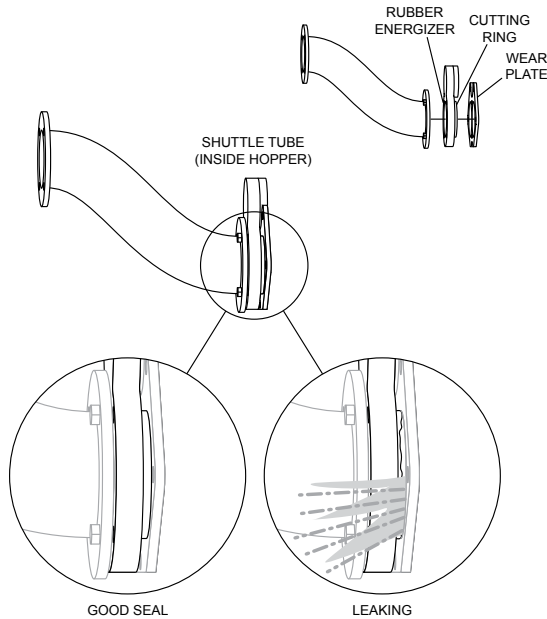

Figure 56. Wear Plate and Cutting Ring

Changing the Concrete Cylinder Piston Cups

The **urethane** piston cups will occasionally require replacement depending on the following factors.

- The fluid level and cleanliness of the lubrication box.
- The size and type of aggregate.
- The type of concrete being pumped.

It is time to replace the cups when increasingly large particles of sand and cement pass into the lubrication box. **DO NOT** allow the cups to become so worn that they begin to pass lubrication into the material cylinders.

If the liquid level of the lubrication box becomes too low, the rubber cups will severely deform due to excessive heat. Whenever replacement is due, both cylinder cups should be replaced.

⚠
DANGER

AMPUTATION HAZARD

During routine maintenance or removing material blockage, you will be required to put your hand in the concrete cylinders or near the shuttle tube. You are at **extreme risk** of injury or **AMPUTATION** if the engine is running or if pressure is in the hydraulic system.

Prior to performing any maintenance on the pump, follow described lock out-tag out procedures. Stop the engine by turning off the ignition switch and remove the starter key.

Place a **DO NOT OPERATE** tag over the switch and disconnect the battery. The pressure reading on the accumulator pressure gauge **MUST** read **zero**. **ALWAYS** make sure the accumulator circuit pressure reads zero prior to performing any maintenance on the pump.

Cylinder Cup Replacement Procedure

1. Remove the two hydraulic hoses connected to the remix motor. Plug the ports with fittings (not provided) to prevent hydraulic hose leakage.
2. Remove the hopper discharge nipple and loosen sleeve seal. Inspect and replace if wear is excessive.
3. Remove the two tie rod nuts and the four eyebolt nuts securing the hopper to the pump frame.
4. Using an approved lifting device, remove the hopper using extreme care not to damage the hopper seal.
5. Start the engine and turn on the pressure test switch. Cycle pump in reverse until hydraulic system obtains maximum pressure, then turn pump and engine off.
6. Remove ignition key and disconnect battery. **Think safety!** Check the hydraulic gauges on panel and make sure accumulator pressure reads zero. One piston should be in the fully discharged position at the end of the concrete cylinder.

7. Remove the three 3/8 – 16 x 3” bolts from the piston. Remove the front faceplate.
8. Install two the 3/8’ 16x3” bolts back into the piston – do not tighten. Use the two bolts as leverage to remove the rubber piston cup and rear components.
9. Obtain two 3/8 16x7” full thread studs (these studs will be used to assist in assembly alignment) insert the two studs into the piston adapter. Coat the concrete cylinder with grease.
10. Install the “O” Ring around the oiler plate. Install the plate into the concrete cylinder utilizing the studs for alignment.

NOTICE

Felt ring must be saturated with 30 wt. oil prior to installation.

11. Install the felt holder over the oiler plate. Install felt ring into felt holder. Install the bronze ring.
12. Using silicon sealant place a small bead of sealant material on the front of the rubber piston cup and the rear of the face plate. Install over alignment studs and into concrete cylinders.
13. Insert one 3/8” 16x3” bolt into the open bolt hole, remove the alignment studs one at a time and install the remaining 3/8” 16x3” bolts.

NOTICE

Before installing 3/8” bolts, coat the back of bolt heads with silicon sealant. Torque all three bolts equal at 55 ft. lbs. each.

Wear Plate And Cutting Ring Replacement

Due to the swinging motion of the **nun-plate** and the abrasive nature of concrete, it is normal for the cutting ring to wear on the side that shears through the concrete inside the hopper.

If the wear ring and wear plate do not fully seat against each other the concrete slurry will pump into the hopper. This condition can be easily observed by the sudden change of the level of concrete inside the hopper during each stroke.

1. Remove the two hydraulic hoses connected to the remix motor. Plug the ports with fittings (not provided) to prevent hydraulic hose leakage.
2. Remove the hopper discharge nipple and loosen sleeve seal. Inspect and replace if wear is excessive.
3. Remove the two tie rod nuts and the four eyebolt nuts securing the hopper to the pump frame.
4. Using an approved lifting device, remove the hopper using extreme care not to damage the hopper seal.
5. Remove the four 1/2” 1-1/4” bolts that hold the shuttle tube to the nun-plate and remove shuttle tube.
6. Using two small pry bars remove the rubber energizer ring, steel insert ring and wear ring.

NOTICE

The energizer ring and wear ring will normally have concrete contamination holding them in position. It will be required to chip some of the concrete loose to better expose the energizer ring.

7. Clean out all concrete build up in and around the nun-plate area with a wire brush.
8. Inspect the wear components for indications of wear. The wear plate has two wear surfaces.

Wear Plate Installation

1. Install the two cylinder **o-rings**.
2. Using silicon sealant, coat the circumference of the concrete cylinders, the back of the wear plate and around the five bolt holes. Next, install the wear plate and the five bolts. The bolts must all be equally snugged and tightened to 100 foot pounds each.

Wear Ring Installation

1. Install the wear ring into the **nun plate**.
2. Install the steel insert ring inside of the rubber energizer ring.
3. Install the energizer ring assembly into the nun plate.
4. After installing the above mentioned components the machine can be reassembled by reversing steps 1 through 5 of the Wear Plate and Cutting Ring Replacement Procedure.

Heat Exchanger Cooling Fan

This section is intended to make sure the cooling fan is working properly. Under normal conditions the fan should be running any time the engine is turned on.

NOTICE

If the hydraulic oil temperature exceeds 170° F (77° C), shut down the pump. **DO NOT** continue to operate the pump. Failure to shut down the pump will result in severe damage to the pump.

Pressure Test

- To determine the pressure of the hydraulic system, set the **cylinder stroke control switch** (Figure 57) to the **JOG** position.

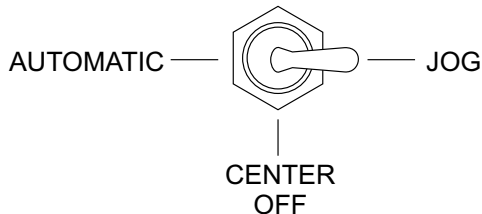

Figure 57. Cylinder Stroke Control Switch (JOG)

- Place and hold the **manual cylinder jogging switch** (Figure 58) to either **JOG "A"** or **JOG "B"** position to test the pressure of that cylinder.

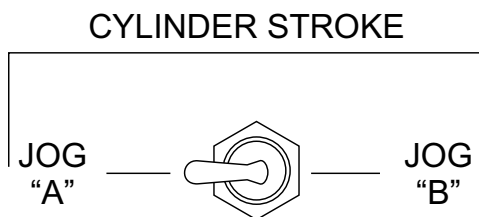

Figure 58. Manual Cylinder Jogging Switch

- The **pumping pressure gauge** (Figure 59) should read approximately 4300 ~ 4400 PSI.

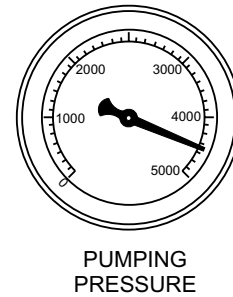

Figure 59. Pumping Pressure Gauge

Long Term Storage (Pump)

- Remove the battery.
- Drain the fuel tank completely. Treat with a fuel stabilizer if necessary.
- Clean exterior with a cloth soaked in clean oil.
- Store unit covered with plastic sheet in moisture and dust-free location out of direct sunlight.

CAUTION

NEVER store the pump with fuel in the tank for any extended period of time. **ALWAYS** clean up spilled fuel immediately.

Long Term Storage (Trailer)

- Check brake system for proper fluid level in master cylinder and bleed all lines.
- Lubricate all links and pivots to prevent any rusting.
- Remove wheel and drum assemblies and spray a good anti-corrosion compound (CRC formula 5-56) under rubber boot on forward end of brake wheel cylinder. Avoid spraying drum and brake lining.
- Grease all bearings and reinstall wheel and drum assemblies.
- Make sure breakaway cable is fully released.
- After extended storage, refer to the Maintenance Steps listed above to insure that the trailer is ready for towing.

TRAILER MAINTENANCE

The following trailer maintenance guidelines are intended to assist the operator in preventive maintenance.

TRAILER BRAKES

Properly functioning brake shoes and drums are essential to ensure safety. The brakes should be inspected the first 200 miles of operation. This will allow the brake shoes and drums to seat properly. After the first 200 mile interval, inspect the brakes every 3,000 miles. If driving over rough terrain, inspect the brakes more frequently.

HYDRAULIC BRAKES

If your trailer has hydraulic brakes, they function the same way the surge brakes do on your tow vehicle. The hydraulic braking system must be inspected at least as often as the brakes on the tow vehicle, but no less than once per year. This inspection includes an assessment of the condition and proper operation of the wheel cylinders, brake shoes, brake drums and hubs.

MANUALLY ADJUSTING THE BRAKES

Most axles are fitted with a brake mechanism that will adjust the brakes during a hard stop. However, some braking systems are not automatically adjusted by hard stopping. These brakes require manual adjustment. The following steps apply to adjust most manually adjustable brakes.

1. Jack up the trailer and secure it on adequate capacity jackstands.
2. Be sure the wheel and brake drum rotate freely.
3. Remove the adjusting-hole cover from the adjusting slot on the bottom of the brake backing plate.
4. With a screwdriver or standard adjusting tool, rotate the starwheel of the adjuster assembly to expand the brake shoes. Adjust the brake shoes out until the pressure of the linings against the drum makes the wheel very difficult to turn. Note: Your trailer maybe equipped with drop spindle axles. See axle manual for your axle type. You will need a modified adjusting tool for adjusting the brakes in these axles. With drop spindle axles, a modified adjusting tool with about an 80 degree angle should be used.
5. Rotate the starwheel in the opposite direction until the wheel turns freely with a slight drag.
6. Replace the adjusting-hole cover.

7. Repeat the above procedure on all brakes.
8. Lower the trailer to the ground.

Check the fluid level in the master cylinder reservoir at least every three months. If you tow your trailer an average of 1,000 miles per month in a hot and dry environment, you must check the brake fluid level once a month. The brake fluid reservoir is located on the tongue of the trailer. Always fill with clean, uncontaminated DOT 4 brake fluid.

Figure 60 below displays the major hydraulic brake components that will require inspection and maintenance. Please inspect these components as required using steps 1 through 6 as referenced in the “Manually Adjusting The Brakes” section on this page. See Table 8 for Hydraulic Brake Troubleshooting.

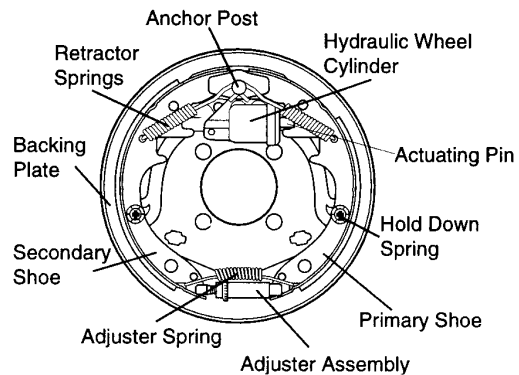

Figure 60. Hydraulic Brake Components

HYDRAULIC BRAKE ACTUATOR

The hydraulic brake actuator (Figure 61) is the mechanism that activates the trailer's brake system. This actuator changes fluid power into mechanical power. Therefore, the fluid level must be checked frequently to assure that the brakes function properly.

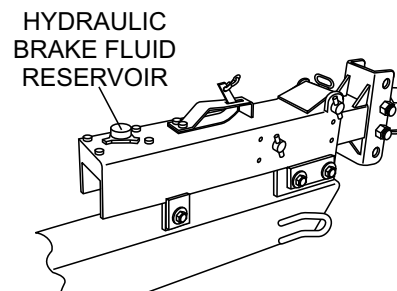

Figure 61. Hydraulic Brake Actuator

TRAILER MAINTENANCE

WARNING

Failure to maintain proper fluid level in the actuator may result in loss of braking action which could cause severe property damage, injury or death.

Periodically check the actuator mounting fasteners for damage or loosening. Inspect the actuator for worn or damaged parts. As you are towing your trailer, be aware of any changes in braking quality. This could be an early warning of brake or actuator malfunction and requires immediate attention. Consult a certified brake specialist to make necessary adjustment or repairs

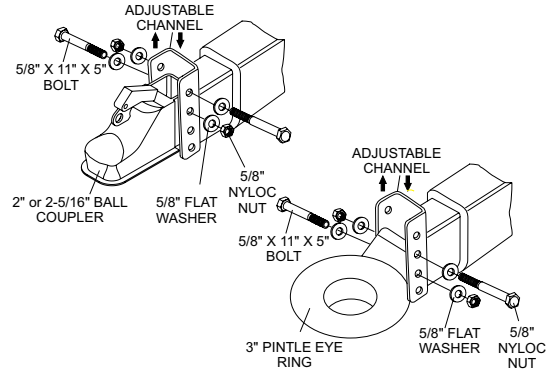

Figure 62. Adjustable Channel

Table 8. Hydraulic Brake Troubleshooting		
Symptom	Possible Cause	Solution
No Brakes	Brake line broken or kinked?	Repair or replace.
Weak Brakes or Brakes Pull to One Side	Brake lining glazed?	Reburnish or replace.
	Trailer overloaded?	Correct weight.
	Brake drums scored or grooved?	Machine or replace.
	Tire pressure correct?	Inflate all tires equally.
	Tires unmatched on the same axle?	Match tires.
Locking Brakes	Brake components loose, bent or broken?	Replace components.
	Brake drums out-of-round?	Replace.
Noisy Brakes	System lubricated?	Lubricate.
	Brake components correct?	Replace and correct.
Dragging Brakes	Brake lining thickness incorrect or not adjusted correctly?	Install new shoes and linings.
	Enough brake fluid or correct fluid?	Replace rubber parts fill with dot 4 fluid.

Wheel Bearings

Wheel bearings (Figure 62) must be inspected and lubricated once a year or 12,000 miles to insure safe operation of your trailer.

If trailer wheel bearings are immersed in water, they must be replaced.

DANGER

If trailer wheels are under water for a long period of time, wheel bearings may fail. If this is the case, service wheel bearings immediately.

The possibility exists of the wheels falling off causing equipment damage and severe bodily harm even death!

If the trailer has not been used for an extended amount of time, have the bearings inspected and packed more frequently, at least every six months and prior to use.

Follow the steps below to disassemble the wheel hub and service the wheel bearings. See Figure 63.

ADJUSTABLE CHANNEL

Your trailer may be equipped with an adjustable channel (Figure 62) that allows the coupler to be raised or lowered to a desired height. Periodically check the channel bolts for damage or loosening.

NOTICE

When replacing channel mounting hardware (nuts, bolts and washers), **NEVER** substitute standard hardware. Pay close attention to **bolt length** and **grade**. **ALWAYS** use manufacturer's recommended parts when replacing channel mounting hardware.

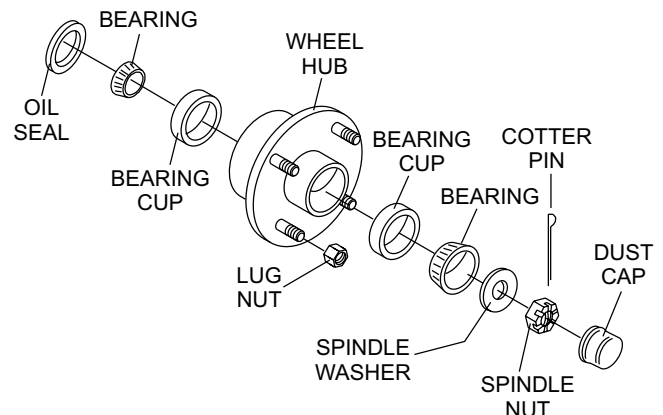

Figure 63. Wheel Hub Components

TRAILER MAINTENANCE

- After removing the dust cap, cotter pin, spindle nut and spindle washer, remove the hub to inspect the bearings for wear and damage.
- Replace bearings that have flat spots on rollers, broken roller cages, rust or pitting. Always replace bearings and cups in sets. The inner and outer bearings are to be replaced at the same time.
- Replace seals that have nicks, tears or wear.
- Lubricate the bearings with a high quality EP-2 automotive wheel bearing grease.

WHEEL HUB ADJUSTMENT

Every time the wheel hub is removed and the bearings are reassembled, follow the steps below to check the wheel bearings for free running and adjust.

- Turn the hub slowly, by hand, while tightening the spindle nut until you can no longer turn the hub by hand.
- Loosen the spindle nut just until you are able to turn it (the spindle nut) by hand. Do not turn the hub while the spindle nut is loose.
- Install a new cotter pin through the spindle nut and axle.
- Check the adjustments. Both the hub and the spindle nut should be able to move freely (the spindle nut motion will be limited by the cotter pin).

! DANGER

NEVER crawl under the trailer unless it is on firm and level ground and resting on properly placed and secured jackstands.

The possibility exists of the trailer falling thus causing equipment damage and severe bodily harm even death!

! DANGER

When performing trailer inspection and maintenance activities, you must jack up the trailer using jacks and jackstands.

When jacking and using jackstands, place them so as to clear wiring, brake lines, and suspension parts (i.e., springs, torsion bars). Place jacks and jackstands inside of the perimeter strip on the supporting structure to which the axles are attached.

! DANGER

Improper weld repair will lead to early failure of the trailer structure and can cause serious injury or death.

DO NOT repair cracked or broken welds unless you have a certified welder perform the repair. If not, have the welds repaired by your dealer.

! WARNING

If the trailer is involved in an accident, have it inspected immediately by qualified personnel. In addition, the trailer should be inspected annually for signs of wear or deformations.

TORSION SUSPENSION

The mounting bracket and associated components (Figure 64) should be visually inspected every 6,000 miles for signs of excessive wear, elongation of bolt holes, and loosening of fasteners. Replace all damaged parts immediately.

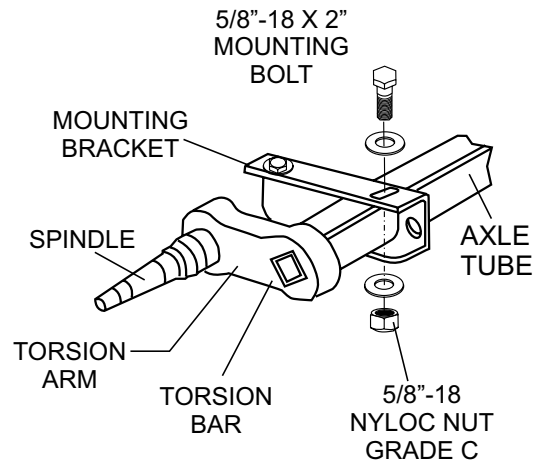

Figure 64. Torsion Suspension Components

! DANGER

Worn or broken suspension parts can cause loss of control, damage to equipment and severe bodily injury, even death!

Check suspension regularly.

TRAILER GUIDELINES

The following guidelines are intended to assist the operator in the operation and handling of a trailer.

Safety precautions should be followed at all times when operating a trailer. Failure to read, understand and follow the safety guidelines could result in injury to yourself and others. Loss of control of the trailer or tow vehicle can result in death or serious injury.

COMMON CAUSES FOR LOSS OF TRAILER

- Driving too fast for the conditions (maximum speed when towing a trailer is 55 mph).
- Overloading the trailer or loading the trailer unevenly.
- Trailer improperly coupled to the hitch.
- No braking on trailer.
- Not maintaining proper tire pressure.
- Not keeping lug nuts tight.
- Not properly maintaining the trailer structure.
- Ensure machine is towed level to tow vehicle.

TRAILER TOWING GUIDELINES

- Recheck the load tiedowns to make sure the load will not shift during towing.
- Before towing, check coupling, safety chain, safety brake, tires, wheels and lights.
- Check the lug nuts or bolts for tightness.
- Check coupler tightness after towing 50 miles.
- Use your mirrors to verify that you have room to change lanes or pull into traffic.
- Use your turn signals well in advance. Allow plenty of stopping space for your trailer and tow vehicle.
- Allow plenty of stopping space for your trailer and tow vehicle.
- **DO NOT** drive so fast that the trailer begins to sway due to speed.
- Allow plenty of room for passing. A rule of thumb is that the passing distance with a trailer is 4 times the passing distance without the trailer.

- Shift your automatic transmission into a lower gear for city driving.
- **ALWAYS** use lower gears for climbing and descending grades.
- **DO NOT** ride the brakes while descending grades, they may get so hot that they stop working. Then you will potentially have a runaway tow vehicle and trailer.
- To conserve fuel, don't use full throttle to climb a hill. Instead, build speed on the approach.
- Slow down for bumps in the road. Take your foot off the brake when crossing the bump.
- **DO NOT** brake while in a curve unless absolutely necessary. Instead, slow down before you enter the curve and power through the curve. This way, the towing vehicle remains in charge.
- **DO NOT** apply the brakes to correct extreme trailer swaying. Continued pulling of the trailer, and even slight acceleration, will provide a stabilizing force.
- Anticipate the trailer "swaying." Swaying is the trailer reaction to the air pressure wave caused by passing trucks and buses. Continued pulling of the trailer provides a stabilizing force to correct swaying. **DO NOT** apply the brakes to correct trailer swaying.
- Use lower gear when driving down steep or long grades. Use the engine and transmission as a brake. Do not ride the brakes, as they can overheat and become ineffective.
- Be aware of your trailer height, especially when approaching roofed areas and around trees.
- Make regular stops, about once each hour. Confirm that:
 - Coupler is secure to the hitch and is locked.
 - Electrical connectors are secure.
 - There is appropriate slack in the safety chains.
 - There is appropriate slack in the breakaway switch pullpin cable.
 - Tires are not visibly low on pressure.

TRAILER GUIDELINES

DRIVING CONDITIONS

When towing a trailer, you will have decreased acceleration, increased stopping distance, and increased turning radius (which means you must make wider turns to keep from hitting curbs, vehicles, and anything else that is on the inside corner). In addition, you will need a longer distance to pass, due to slower acceleration and increased length.

- Be alert for slippery conditions. You are more likely to be affected by slippery road surfaces when driving a tow vehicle with a trailer, than driving a tow vehicle without a trailer.
- Check rearview mirrors frequently to observe the trailer and traffic.
- **NEVER** drive faster than what is safe.

WARNING

Driving too fast for severe road conditions can result in loss of control and cause death or serious injury.

Decrease your speed as road, weather, and lighting conditions deteriorate.

Always check for local trailer tow speed limits in your area.

WARNING

Do not transport people on the trailer. The transport of people puts their lives at risk and may be illegal.

COUPLING TO THE TOW VEHICLE

Follow all of the safety precautions and instructions in this manual to ensure safety of persons, equipment, and satisfactory life of the trailer. Always use an adequate tow vehicle and hitch. If the vehicle or hitch is not properly selected and matched to the Gross Vehicle Weight Rating (GVWR) of your trailer, you can cause an accident that could lead to death or serious injury.

If you already have a tow vehicle, know your vehicle tow rating and make certain the trailer's rated capacity is less than or equal to the tow vehicle's rated towing capacity. If you already have (or plan to buy) a trailer, make certain that the tow rating of the tow vehicle is equal to or greater than that of the trailer.

The trailer VIN tag contains the critical safety information

for the use of your trailer. Again, be sure your hitch and tow vehicle are rated for the Gross Vehicle Weight Rating of your trailer.

WARNING

Proper selection and condition of the coupler and hitch are essential to safely towing your trailer. A loss of coupling may result in death or serious injury.

- Be sure the hitch load rating is equal to or greater than the load rating of the coupler.
- Be sure the hitch size matches the coupler size.
- Observe the hitch for wear, corrosion and cracks before coupling. Replace worn, corroded or cracked hitch components before coupling the trailer to the tow vehicle.
- Be sure the hitch components are tight before coupling the trailer to the tow vehicle.

WARNING

An improperly coupled trailer can result in death or serious injury.

DO NOT move the trailer until:

- The coupler is secured and locked to hitch.
- The safety chains are secured to the tow vehicle.
- The trailer jack(s) are fully retracted.

DO NOT tow the trailer on the road until:

- Tires and wheels are checked.
- The trailer brakes are checked.
- The breakaway switch is connected to the tow vehicle.
- The load is secured to the trailer.
- The trailer lights are connected and checked.

WARNING

Use of a hitch with a load rating less than the load rating of the trailer can result in loss of control and may lead to death or serious injury.

Use of a tow vehicle with a towing capacity less than the load rating of the trailer can result in loss of control, and may lead to death or serious injury.

Be sure your hitch and tow vehicle are rated for the Gross Vehicle Weight Rating of your trailer.

TRAILER GUIDELINES

INOPERABLE BRAKES, LIGHTS OR MIRRORS

Be sure that the brakes and all of the lights on your trailer are functioning properly before towing your trailer. Check the trailer taillights by turning on your tow vehicle headlights. Check the trailer brake lights by having someone step on the tow vehicle brake pedal while you look at trailer lights. Do the same thing to check the turn signal lights. See Trailer Wiring Diagram section in this manual.

Standard mirrors usually do not provide adequate visibility for viewing traffic to the sides and rear of a towed trailer. You must provide mirrors that allow you to safely observe approaching traffic.

WARNING

Improper electrical connection between the tow vehicle and the trailer will result in inoperable lights and can lead to collision.

Before each tow, check that the tail lights, brake lights and turn signals work.

TRAILER TOWING TIPS

Driving a vehicle with a trailer in tow is vastly different from driving the same vehicle without a trailer in tow. Acceleration, maneuverability and braking are all diminished with a trailer in tow.

It takes longer to get up to speed, you need more room to turn and pass, and more distance to stop when towing a trailer. You will need to spend time adjusting to the different feel and maneuverability of the tow vehicle with a loaded trailer.

Because of the significant differences in all aspects of maneuverability when towing a trailer, the hazards and risks of injury are also much greater than when driving without a trailer. You are responsible for keeping your vehicle and trailer in control, and for all the damage that is caused if you lose control of your vehicle and trailer.

As you did when learning to drive an automobile, find an open area with little or no traffic for your first practice trailering. Of course, before you start towing the trailer, you must follow all of the instructions for inspection, testing, loading and coupling. Also, before you start towing, adjust the mirrors so you can see the trailer as well as the area to the rear of it.

Drive slowly at first, 5 mph or so, and turn the wheel to get the feel of how the tow vehicle and trailer combination responds. Next, make some right and left hand turns. Watch in your side mirrors to see how the trailer follows the tow vehicle. Turning with a trailer attached requires more room.

Stop the rig a few times from speeds no greater than 10 mph. If your trailer is equipped with brakes, try using different combinations of trailer brake and tow vehicle brake. Note the effect that the trailer brakes have when they are the only brakes used. When properly adjusted, the trailer brakes will come on just before the tow vehicle brakes.

It will take practice to learn how to back up a tow vehicle with a trailer attached. Take it slow. Before backing up, get out of the tow vehicle and look behind the trailer to make sure that there are no obstacles.

Some drivers place their hands at the bottom of the steering wheel, and while the tow vehicle is in reverse, “think” of the hands as being on the top of the wheel. When the hands move to the right (counterclockwise, as you would do to turn the tow vehicle to the left when moving forward), the rear of the trailer moves to the right. Conversely, rotating the steering wheel clockwise with your hands at the bottom of the wheel will move the rear of the trailer to the left while backing up.

If you are towing a bumper hitch rig, be careful not to allow the trailer to turn too much because it will hit the rear of the tow vehicle. To straighten the rig, either pull forward or turn the steering wheel in the opposite direction.

TRAILER VIN TAG

Figure A below is a sample of the Vehicle Identification Number (VIN) Tag which is typically located on the left front of the trailer. See Figure B for location.

MANUFACTURED BY / FABRIQUE PAR:		DATE	
GVWR / PNBV	KG (LB)	
GAWR (EACH AXLE) / PNBE (CHAQUE ESSIEU)	KG (LB)	TIRES / PNEUS
RIMS / JANTES			
COLD INFL. PRESS. / PRESS. DE GONFL. A FROID	KPA (PSI / LPC <input checked="" type="checkbox"/> SINGLE <input type="checkbox"/> DUAL
THIS VEHICLE CONFORMS TO ALL APPLICABLE U.S. FEDERAL MOTOR VEHICLE SAFETY STANDARDS IN EFFECT ON THE DATE OF MANUFACTURE SHOWN ABOVE.			
THIS VEHICLE CONFORMS TO ALL APPLICABLE STANDARDS PRESCRIBED UNDER THE CANADIAN MOTOR VEHICLE SAFETY REGULATIONS IN EFFECT ON THE DATE OF MANUFACTURE - CE VEHICULE EST CONFORME A TOUTES LES NORMES QUI LUI SONT APPLICABLES EN VERTU DU REGLEMENT SUR LA SECURITE DES VEHICULES AUTOMOBILES DU CANADA EN VIGUEUR A LA DATE DE SA FABRICATION.			
V.I.N. / N.I.E.V.:	TYPE / TYPE: TRAILER TRA / REM		FD-306 REV A

Figure A. Vehicle VIN Tag

TRAILER GUIDELINES

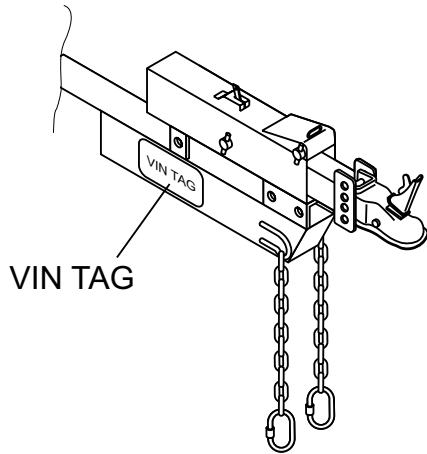

Figure B. VIN Tag Location

The trailer VIN Tag contains the following critical safety information for the use of your trailer.

GAWR: The maximum gross weight that an axle can support. It is the lowest of axle, wheel, or tire rating.

Usually, the tire or wheel rating is lower than the axle rating, and determines GAWR.

GVWR: The maximum allowable gross weight of the trailer and its contents. The gross weight of the trailer includes the weight of the trailer and all of the items within it. GVWR is sometimes referred to as GTWR (Gross Trailer Weight Rating), or MGTW (Maximum Gross Trailer Weight). GVWR, GTWR and MGTW are all the same rating.

The sum total of the GAWR for all trailer axles may be less than the GVWR for the trailer, because some of the trailer load is to be carried by the tow vehicle, rather than by the trailer axle(s). The total weight of the cargo and trailer must not exceed the GVWR, and the load on an axle must not exceed its GAWR.

PSIC: The tire pressure (psi) measured when cold.

VIN: The Vehicle Identification Number.

EMPTY WEIGHT: Some information that comes with the trailer (such as the Manufacturer's Statement of Origin) is not a reliable source for "empty" or "net" weight. The shipping documents list average or standard weights and your trailer may be equipped with options.

To determine the "empty" or "net" weight of your trailer, weigh it on an axle scale. To find the weight of the trailer using an axle scale, you must know the axle weights of your tow vehicle without the trailer coupled. Some of the trailer weight will be transferred from the trailer to the tow vehicle axles, and an axle scale weighs all axles, including the tow vehicle axles.

TOW VEHICLE

The towing hitch attached to your tow vehicle must have a capacity equal to or greater than the load rating of the trailer you intend to tow. The hitch capacity must also be matched to the tow vehicle capacity. Your vehicle dealer can provide and install the proper hitch on your tow vehicle.

SUSPENSION SYSTEM

Sway bars, shock absorbers, heavy duty springs, heavy duty tires and other suspension components may be required to sufficiently tow the trailer and pump.

BRAKE CONTROLLER

For trailers equipped with electric brakes, the electric brake controller is part of the tow vehicle and is essential in the operation of the electric brakes on the trailer. The brake controller is not the same as the safety breakaway brake system that may be equipped on the trailer.

SIDE VIEW MIRRORS

The size of the trailer that is being towed and your state law regulations determine the size of the mirrors. However, some states prohibit extended mirrors on a tow vehicle, except while a trailer is actually being towed. In this situation, detachable extended mirrors are necessary. Check with your dealer or the appropriate state agency for mirror requirements.

HEAVY DUTY FLASHER

A Heavy Duty Flasher is an electrical component that may be required when your trailer turn signal lights are attached to the tow vehicle flasher circuit.

ELECTRICAL CONNECTOR

An Electrical Connector connects the light and brake systems on the trailer to the light and brake controls on the towing vehicle.

TRAILER GUIDELINES

EMERGENCY FLARES AND TRIANGLE REFLECTORS

It is wise to carry these warning devices even if you are not towing a trailer. It is particularly important to have these when towing a trailer because the hazard flashers of your towing vehicle will not operate for as long a period of time when the battery is running both the trailer lights and tow vehicle lights.

SAFETY CHAINS

If the coupler connection comes loose, the safety chains can keep the trailer attached to the tow vehicle. With properly rigged safety chains, it is possible to keep the tongue of the trailer from digging into the road pavement, even if the coupler-to-hitch connection comes apart.

TRAILER LIGHTING AND BRAKING CONNECTOR

A device that connects electrical power from the tow vehicle to the trailer. Electricity is used to turn on brake lights, running lights, and turn signals as required. In addition, if your trailer has a separate braking system, the electrical connector will also supply power to the brakes from the tow vehicle.

BREAKAWAY SYSTEM

If the trailer coupler connection comes loose, the breakaway system can actuate emergency hydraulic brakes depending on the type of actuator on the trailer. The breakaway cable must be rigged to the tow vehicle with appropriate slack that will activate the system if the coupler connection comes loose.

JACKSTAND

A device on the trailer that is used to raise and lower the coupler. The jack is sometimes called the “landing gear” or the “tongue jack”.

COUPLER TYPES

Two types of coupler used with the trailer are discussed below.

- Ball Hitch Coupler
- Pintel Eye Coupler

BALL HITCH COUPLER

A ball hitch coupler (Figure C) connects to a ball that is located on or under the rear bumper of tow vehicle. This system of coupling a trailer to a tow vehicle is sometimes referred to as “bumper pull.”

A ball hitch trailer may be fitted with a tongue jack that can raise and lower the coupler. The tongue jack is mounted to the A-frame (front or tongue) part of the trailer. By rotating the jack handle clockwise, the jack will extend and raise the tongue of the trailer.

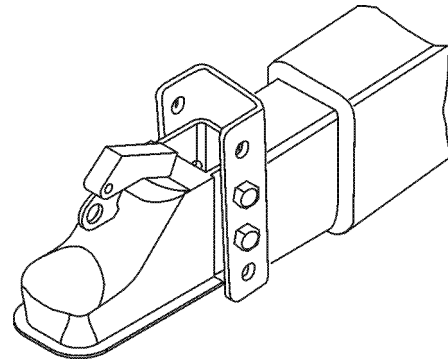

Figure C. Ball Hitch Coupler

Before each tow, coat the ball with a thin layer of automotive bearing grease to reduce wear and ensure proper operation. Check the locking device that secures the coupler to the ball for proper operation.

If you see or feel evidence of wear, such as flat spots, deformations, pitting or corrosion, on the ball or coupler, immediately have your dealer inspect them to determine the proper action to prevent possible failure of the ball and coupler system. All bent or broken coupler parts must be replaced before towing the trailer.

The coupler handle lever must be able to rotate freely and automatically snap into the latched position. Oil the pivot points, sliding surfaces, and spring ends with SAE 30W motor oil. Keep the ball socket and latch mechanism clean. Dirt or contamination can prevent proper operation of the latching mechanism.

The load rating of the coupler and the necessary ball size are listed on the trailer tongue. You must provide a hitch and ball for your tow vehicle where the load rating of the hitch and ball is equal to or greater than that of your trailer.

Also, the ball size must be the same as the coupler size. If the hitch ball is too small, too large, is underrated, is loose

TRAILER GUIDELINES

or is worn, the trailer can come loose from the tow vehicle and may cause death or serious injury.

THE TOW VEHICLE, HITCH AND BALL MUST HAVE A RATED TOWING CAPACITY EQUAL TO OR GREATER THAN THE TRAILER **Gross Vehicle Weight Rating (GVWR)**. IT IS ESSENTIAL THAT THE HITCH BALL BE OF THE SAME SIZE AS THE COUPLER.

The ball size and load rating (capacity) are marked on the ball. Hitch capacity is marked on the hitch.

⚠ WARNING

Coupler-to-hitch mismatch can result in uncoupling, leading to death or serious injury.

Be sure the **LOAD RATING** of the hitch ball is equal or greater than the load rating of the coupler.

Be sure the **SIZE** of the hitch ball matches the size of the ball coupler.

⚠ WARNING

A worn, cracked or corroded hitch ball can fail while towing and may result in death or serious injury.

Before coupling trailer, inspect the hitch ball for wear, corrosion and cracks.

Replace worn or damaged hitch ball.

⚠ WARNING

A loose hitchball nut can result in uncoupling, leading to death or serious injury.

Be sure the hitch ball is tight to the hitch before coupling the trailer.

- Rock the ball to make sure it is tightened to the hitch, and visually check that the hitch ball nut is solid against the lock washer and hitch frame.
- Wipe the inside and outside of the coupler. Clean and visually inspect it for cracks and deformations. Feel the inside of the coupler for worn spots and pits.
- Be sure the coupler is secured tightly to the tongue of the trailer. All coupler fasteners must be visibly solid against the trailer frame.
- The bottom surface of the coupler must be above the top of the hitch ball. Use the tongue jackstand to support

the trailer tongue. Wood or concrete blocks may also be used.

Coupling the Trailer to the Tow Vehicle (Ball Coupler)

- Lubricate the hitch ball and the inside of the coupler with a thin layer of automotive bearing grease.
- Slowly back up the tow vehicle so that the hitch ball is near or aligned under the coupler.
- Using the jackstand at the front of trailer (tongue), turn the jackstand crank handle to raise the trailer. If the ball coupler does not line up with the hitch ball, adjust the position of the tow vehicle.
- Open the coupler locking mechanism. Ball couplers have a locking mechanism with an internal moving piece and an outside handle. In the open position, the coupler is able to drop fully onto the hitch ball.
- Lower the trailer (Figure D) until the coupler fully engages the hitch ball.

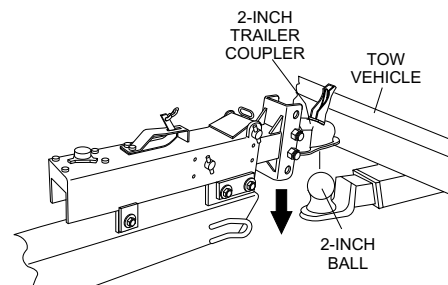

Figure D. Ball Hitch Coupling Mechanism

- Engage the coupler locking mechanism. In the engaged position, the locking mechanism securely holds the coupler to the hitch ball.
- Insert a pin or lock through the hole in the locking mechanism.
- Be sure the coupler is all the way on the hitch ball and the locking mechanism is engaged. A properly engaged locking mechanism will allow the coupler to raise the rear of the tow vehicle. Using the trailer jackstand, verify that you can raise the rear of the tow vehicle by 1 inch after the coupler is locked to the hitch.
- Lower the trailer so that its entire tongue weight is held by the hitch.
- Raise the jackstand to a height where it will not interfere with the road.

TRAILER GUIDELINES

NOTICE

Overloading can damage the tongue jack. **DO NOT** use the tongue jack to raise the tow vehicle more than one inch.

If the coupler cannot be secured to the hitch ball, do not tow the trailer. Call your dealer for assistance. Lower the trailer so that its entire tongue weight is held by the hitch and continue retracting the jack to its fully retracted position.

Attaching Safety Chain

Visually inspect the safety chains and hooks for wear or damage. Replace worn or damaged safety chains and hooks before towing.

Attach the safety chains so that they:

- Cross underneath the coupler. See Figure E.

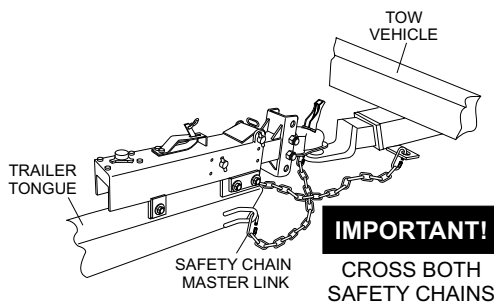

Figure E. Attaching Safety Chain (Ball Hitch)

- Loop around a frame member of the tow vehicle or holes provided in the hitch system (DO NOT attach them to an interchangeable part of the hitch assembly).
- Have enough slack to permit tight turns, but not be close to the road surface, so if the trailer uncouples, the safety chains can hold the tongue up above the road

WARNING

Improper rigging of the safety chains can result in loss of control of the trailer and tow vehicle, leading to death or serious injury, if the trailer uncouples from the tow vehicle.

- Fasten chains to frame of tow vehicle. DO NOT fasten chains to any part of the hitch unless the hitch has holes or loops specifically for that purpose.
- Cross chains underneath hitch and coupler with enough slack to permit turning and to hold tongue up, if the trailer comes loose.

Breakaway Brake System

If the coupler or hitch fails, a properly connected and working breakaway brake system (Figure F) will apply the hydraulic brakes on the trailer. The safety chains will keep the tow vehicle attached and as the brakes are applied at the trailer's axles, the trailer/tow vehicle combination will come to a controlled stop.

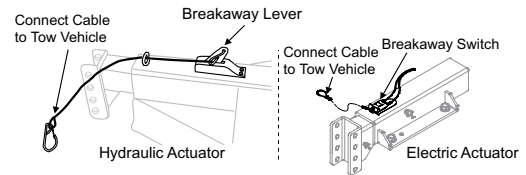

Figure F. Breakaway Brake System

Breakaway Cable Surge Brake System

The breakaway brake system includes a brake cable connected to the tow vehicle on one end and to the emergency brake lever located on the hydraulic actuator on the other end.

WARNING

- An ineffective breakaway brake system can result in a runaway trailer, leading to death or serious injury, if the coupler or ball hitch fails.
- Connect the breakaway cable to the tow vehicle and NOT to the hitch, ball or support.
- Before towing the trailer, test the function of the breakaway brake system. If the breakaway brake system is not working, DO NOT tow the trailer. Have it serviced or repaired.

NOTICE

DO NOT tow the trailer with the breakaway brake system ON because the brakes will overheat which can result in permanent brake failure.

NOTICE

Replace the breakaway brake battery (if equipped) at intervals specified by manufacturer.

TRAILER GUIDELINES

Connecting Trailer Lights

Connect the trailer lights to the tow vehicle's electrical system using the electric connectors at the front of the trailer (tongue). Refer to the wiring diagram shown in the trailer wiring diagram section of this manual. Before towing the trailer check for the following:

- Running lights (turn on tow vehicle headlights).
- Brake Lights (step on tow vehicle brake pedal).
- Backup Lights (place tow vehicle gear shift in reverse).
- Turn Signals (activate tow vehicle directional signal lever).

WARNING

Improper electrical connection between the tow vehicle and the trailer will result in inoperable lights and electric brakes, and can lead to collision.

Before each tow:

- Check that the taillights, brake lights and turn signals work.
- Check that the electric brakes work by operating the brake controller inside the tow vehicle.

Uncoupling the Ball Hitch

Follow these steps to uncouple ball hitch from tow vehicle:

- Block trailer tires to prevent the trailer from rolling, before jacking the trailer up.
- Disconnect the electrical connector.
- Disconnect the breakaway brake switch cable. Promptly replace the pullpin in the switchbox.
- Before extending jackstand, make certain the ground surface below the jackstand foot will support the tongue load.
- Rotate the jackstand handle (or crank) clockwise. This will slowly extend the jack and transfer the weight of the trailer tongue to the jack.

PINTLE HITCH COUPLER

A pintle eye coupler (Figure G) connects to a pintle-hook hitch that is located on or under the rear bumper of the tow vehicle. This system of coupling a trailer to a tow vehicle is sometimes referred to as a "lunette eye, tow ring or G.I. hitch."

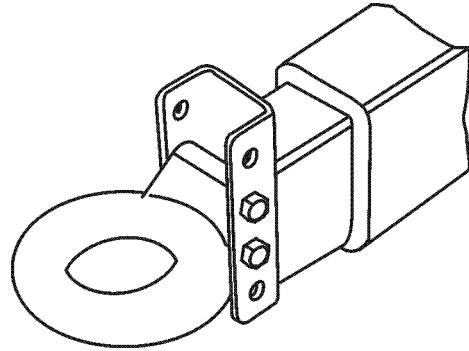

Figure G. Pintle Hitch Coupler

A pintle hitch trailer may be fitted with a tongue jackstand that can raise and lower the coupler. The tongue jack is mounted to the A-frame (front or tongue) part of the trailer. By rotating the jack handle clockwise, the jack will extend and raise the tongue of the trailer.

The load rating of the coupler and the necessary pintle hitch size are listed on the trailer tongue. You must provide a pintle hitch and pintle coupler for your tow vehicle, where the load rating of the pintle hitch and pintle coupler is equal to or greater than that of your trailer.

Also, the pintle hitch size must be the same as the pintle coupler size. If the hitch is too small, too large, underrated, loose or worn, the trailer can come loose from the tow vehicle, and may cause death or serious injury.

Pintle Coupler and Pintle Hook

Before each tow, check the locking device that secures the coupler to the pintle hook assembly.

The pintle hook lever must be able to operate freely and automatically snap into place into the latched position. Lightly oil the pivot points and sliding surfaces with SAE30W motor oil to prevent rust and help ensure proper operation of the latching mechanism.

If you see or feel evidence of wear, such as flat spots, deformations, pitting or corrosion, on the pintle hook or coupler, immediately have your dealer inspect them to determine the proper action to prevent possible failure of

TRAILER GUIDELINES

the ball and coupler system. All bent or broken coupler parts must be replaced before towing the trailer.

THE TOW VEHICLE, PINTLE HITCH AND PINTLE COUPLER MUST HAVE A RATED TOWING CAPACITY EQUAL TO OR GREATER THAN THE TRAILER **Gross Vehicle Weight Rating (GVWR)**.

IT IS ESSENTIAL THAT THE PINTLE HITCH BE OF THE SAME SIZE AS THE PINTLE COUPLER.

The coupler size and load rating (capacity) are marked on the coupler. Hitch capacity is marked on the hitch.

⚠ WARNING

Coupler-to-hitch mismatch can result in uncoupling, leading to death or serious injury.

Be sure the **LOAD RATING** of the pintle hitch hook is equal or greater than the load rating of the pintle eye coupler.

Be sure the **SIZE** of the pintle hitch hook matches the size of the pintle eye coupler.

⚠ WARNING

A worn, cracked or corroded pintle hitch hook can fail while towing, and may result in death or serious injury.

Before coupling trailer, inspect the pintle hitch hook for wear, corrosion and cracks.

Replace worn or damaged pintle hitch hook.

- Rock the pintle eye coupler to make sure it is secured tightly to the hitch.
- Wipe the inside and outside of the pintle coupler. Clean and inspect it visually for cracks and deformations. Feel the inside of the coupler for worn spots and pits.
- Be sure the coupler is secured tightly to the tongue of the trailer. All coupler fasteners must be visibly solid against the trailer frame.
- Raise the bottom surface of the coupler to be above the top of the pintle hitch hook. Use the tongue jackstand to support the trailer tongue. Wood or concrete blocks may also be used.

⚠ WARNING

A defective pintle hitch not properly fastened can result in uncoupling, leading to death or serious injury.

Be sure the pintle hook is securely tightened to the tow vehicle before coupling the trailer.

Coupling Trailer to Tow Vehicle (Pintle Coupler)

- Slowly back up the tow vehicle so that the pintle hitch hook is near or aligned under the pintle eye ring coupler.
- Using the jackstand at the front of trailer (tongue), turn the jackstand crank handle to raise the trailer. If the pintle eye coupler does not line up with the pintle hitch hook, adjust the position of the tow vehicle.
- **OPEN** the pintle hook locking mechanism (Figure H). Place the hook inside the eye coupler. **CLOSE** the pintle hook mechanism.

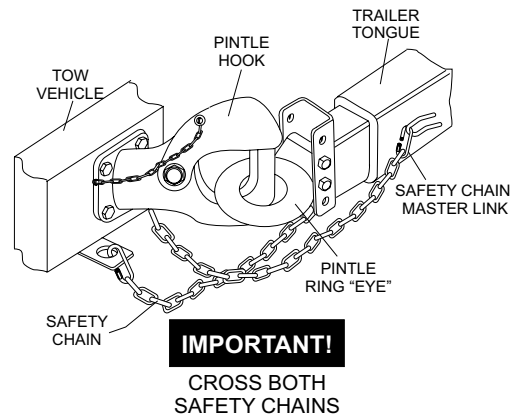

Figure H. Attaching Safety Chain (Pintle Hitch)

- Insert a pin or lock through the hole in the locking mechanism.
- Be sure the pintle hook is inserted completely through the eye ring and the locking mechanism is engaged. A properly engaged locking mechanism will allow the coupler to raise the rear of the tow vehicle. Using the trailer jack, test to see that you can raise the rear of the tow vehicle by 1-inch after the coupler is locked to the hitch.
- Lower the trailer so that its entire tongue weight is held by the hitch.
- Raise the jackstand to a height where it will not interfere with the road.

TRAILER GUIDELINES

TIRE SAFETY

Unsafe Tires, Lug Nuts or Wheels

Trailer tires and wheels are more likely to fail than car tires and wheels because they carry a heavier load. Therefore, it is essential to inspect the trailer tires before each tow.

If a tire has a bald spot, bulge, cuts, is showing any cords, or is cracked, replace the tire before towing. If a tire has uneven tread wear, take the trailer to a dealer service center for diagnosis.

Uneven tread wear can be caused by tire imbalance, axle misalignment or incorrect inflation.

Tires with too little tread will not provide adequate tracking on wet roadways and can result in loss of control, leading to death or serious injury.

Improper tire pressure causes an unstable trailer and can result in a tire blowout and loss of control. Therefore, before each tow you must also check the tire pressure. Tire pressure must be checked when tires are cold.

Allow 3 hours cool-down after driving as much as 1 mile at 40 mph before checking tire pressure. Trailer tires will be inflated to higher pressures than passenger vehicle tires.

Since trailer wheels and lug nuts (or bolts) are subjected to greater side loads than automobile wheels, they are more prone to loosen. Before each tow, check to make sure they are tight.

The proper tightness (torque) for lug nuts is listed in the lug nut tightening section of this manual. Use a torque wrench to tighten the lug nuts. If you do not have a torque wrench, use a lug wrench (from your tow vehicle) and tighten the nuts as much as you can. Then have a service garage or trailer dealer tighten the lug nuts to the proper torque.

WARNING

Metal creep between the wheel rim and lug nuts will cause rim to loosen and could result in a wheel coming off, leading to death or serious injury.

Tighten lug nuts before each tow.

Lug nuts are also prone to loosen after first being assembled. When driving a new trailer (or after wheels have been remounted), check to make sure they are tight after the first 10, 25 and 50 miles of driving and before each tow thereafter.

Failure to perform this check can result in a wheel parting from the trailer and a crash, leading to death or serious injury.

WARNING

Lug nuts are prone to loosen after initial installation, which can lead to death or serious injury.

Check lug nuts for tightness on a new trailer or when wheel(s) have been remounted after the first 10, 25 and 50 miles of driving.

WARNING

Improper lug nut torque can cause a wheel parting from the trailer, leading to death or serious injury.

Be sure lug nuts are tight before each tow.

WARNING

Improper tire pressure can result in a blowout and loss of control, which can lead to death or serious injury.

Be sure tires are inflated to pressure indicated on side wall before towing trailer.

Determining Load Limit of Trailer

Determining the load limits of a trailer includes more than understanding the load limits of the tires alone. On all trailers there is a Federal certification/VIN label that is located on the forward half of the left (road) side of the unit. This certification/VIN label will indicate the trailer's Gross Vehicle Weight Rating (GVWR). This is the most weight the fully loaded trailer can weigh. It will also provide the Gross Axle Weight Rating (GAWR). This is the most a the axle can weigh.

TRAILER GUIDELINES

There is a vehicle placard (Figure I) located in the same location as the certification label described above. This placard provides tire and loading information. In addition, this placard will show a statement regarding maximum cargo capacity.

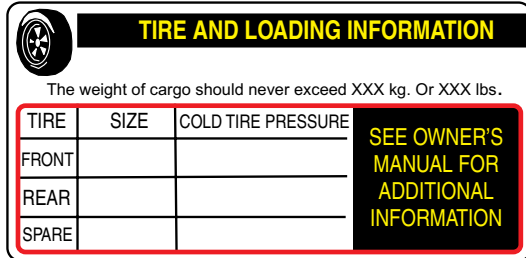

Figure I. Trailer Tire Placard

If additional work items (hoses, tools, clamps etc.) are going to be added to the trailer, be sure they are distributed evenly to prevent overloading front to back and side to side. Heavy items should be placed low and as close to the axle positions as reasonable. Too many items on one side may overload a tire.

Excessive loads and/or underinflation cause tire overloading and, as a result, abnormal tire flexing occurs. This situation can generate an excessive amount of heat within the tire. Excessive heat may lead to tire failure. It is the air pressure that enables a tire to support the load, so proper inflation is critical. The proper air pressure may be found on the certification/VIN label and/or on the Tire and Loading Information placard. This value should never exceed the maximum cold inflation pressure stamped on the tire.

Perform the following steps to determine the load limit of your trailer.

Step 1.

Locate the statement, “The weight of cargo should never exceed XXX kg or XXX lbs.,” on your vehicle’s Tire and Loading Information placard (Figure I). This value equals the available amount of equipment load capacity.

Step 2.

Determine the weight of the equipment being loaded on the tow vehicle. That weight may not safely exceed the available equipment load capacity. The trailer’s Tire Information Placard is attached adjacent to or near the trailer’s VIN (Certification) label at the left front of the trailer (See Figure I).

Determining Load Limit of Tow Vehicle

Step 1.

Locate the statement, “The combined weight of occupants and cargo should never exceed XXX lbs.,” on your vehicle’s placard.

Step 2.

Determine the combined weight of the driver and passengers who will be riding in your vehicle.

Step 3.

Subtract the combined weight of the driver and passengers from XXX kilograms or XXX pounds.

Step 4.

The resulting figure equals the available amount of cargo and luggage capacity. For example, if the “XXX” amount equals 1400 lbs. and there will be five 150 lb. passengers in your vehicle, the amount of available cargo and luggage capacity is 650 lbs. (1400-750 (5 x 150) = 650 lbs.).

Step 5.

Determine the combined weight of luggage and cargo being loaded on the vehicle. That weight may not safely exceed the available cargo and luggage capacity calculated in Step 4.

If your vehicle will be towing a trailer, load from your trailer will be transferred to your vehicle. Consult the tow vehicle’s manual to determine how this weight transfer reduces the available cargo and luggage capacity of your vehicle.

Studies of tire safety show that maintaining proper tire pressure, observing tire and vehicle load limits (not carrying more weight in your vehicle than your tires or vehicle can safely handle), avoiding road hazards and inspecting tires for cuts, slashes and other irregularities are the most important things you can do to avoid tire failure, such as tread separation or blowout and flat tires. These actions, along with other care and maintenance activities, can also:

- Improve vehicle handling.
- Help protect you and others from avoidable breakdowns and accidents.
- Improve fuel economy.
- Increase the tire life.

TRAILER GUIDELINES

Use the information contained in this section to make tire safety a regular part of your vehicle maintenance routine. Recognize that the time you spend is minimal compared with the inconvenience and safety consequences of a flat tire or other tire failure.

TIRE FUNDAMENTALS

Federal law requires tire manufacturers to place standardized information on the sidewall of all tires (Figure J). This information identifies and describes the fundamental characteristics of the tire and also provides a tire identification number for safety standard certification and in case of a recall.

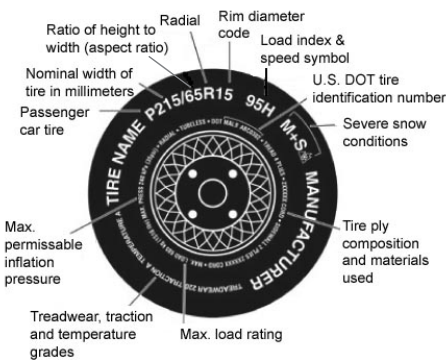

Figure J. Standard Tire Sidewall Information

P: The “P” indicates the tire is for passenger vehicles.

Next number: This three-digit number gives the width in millimeters of the tire from sidewall edge to sidewall edge. In general, the larger the number, the wider the tire.

Next number: This two-digit number, known as the aspect ratio, gives the tire’s ratio of height to width. Numbers of 70 or lower indicate a short sidewall for improved steering response and better overall handling on dry pavement.

P: The “R” stands for radial. Radial ply construction of tires has been the industry standard for the past 20 years.

Next number: This two-digit number is the wheel or rim diameter in inches. If you change your wheel size, you will have to purchase new tires to match the new wheel diameter.

Next number: This two- or three-digit number is the tire’s load index. It is a measurement of how much weight each tire can support. You may find this information in your owner’s manual. If not, contact a local tire dealer. *Note:* You may not find this information on all tires because it is not required by law.

M+S: The “M+S” or “M/S” indicates that the tire has some mud and snow capability. Most radial tires have these markings; hence, they have some mud and snow capability.

Speed Rating: The speed rating denotes the speed at which a tire is designed to be driven for extended periods of time. The ratings range from 99 miles per hour (mph) to 186 mph. These ratings are listed in Table A. *Note:* You may not find this information on all tires because it is not required by law.

Letter Rating	Speed Rating
Q	99 mph
R	106 mph
S	112 mph
T	118 mph
U	124 mph
H	130 mph
V	149 mph
W	168* mph
Y	186* mph

U.S. DOT Tire Identification Number: This begins with the letters “DOT” and indicates that the tire meets all federal standards. The next two numbers or letters are the plant code where it was manufactured, and the last four numbers represent the week and year the tire was built. For example, the numbers 3197 means the 31st week of 1997. The other numbers are marketing codes used at the manufacturer’s discretion. This information is used to contact consumers if a tire defect requires a recall.

Tire Ply Composition and Materials Used: The number of plies indicates the number of layers of rubber-coated fabric in the tire. In general, the greater the number of plies, the more weight a tire can support. Tire manufacturers also must indicate the materials in the tire, which include steel, nylon, polyester, and others.

Maximum Load Rating: This number indicates the maximum load in kilograms and pounds that can be carried by the tire.

Maximum Permissible Inflation Pressure: This number is the greatest amount of air pressure that should ever be put in the tire under normal driving conditions.

Uniform Tire Quality Grading Standards (UTQGS)

Treadwear Number: This number indicates the tire's wear rate. The higher the treadwear number is, the longer it should take for the tread to wear down. For example, a tire graded 400 should last twice as long as a tire graded 200.

Traction Letter: This letter indicates a tire's ability to stop on wet pavement. A higher graded tire should allow you to stop your car on wet roads in a shorter distance than a tire with a lower grade. Traction is graded from highest to lowest as "AA", "A", "B", and "C".

Temperature Letter: This letter indicates a tire's resistance to heat. The temperature grade is for a tire that is inflated properly and not overloaded. Excessive speed, underinflation or excessive loading, either separately or in combination, can cause heat build-up and possible tire failure. From highest to lowest, a tire's resistance to heat is graded as "A", "B", or "C".

Refer to Figure K for additional tire information for light trucks.

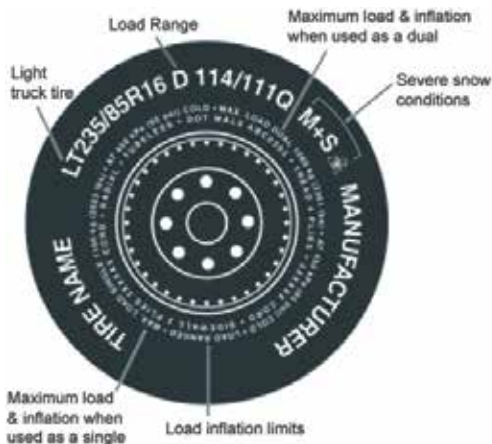

Figure K. UTQGS Tire Information

Tires for light trucks have other markings besides those found on the sidewalls of passenger tires.

LT: The "LT" indicates the tire is for light trucks or trailers.

ST: An "ST" is an indication the tire is for trailer use only.

Max. Load Dual kg (lbs) at kPa (psi) Cold: This information indicates the maximum load and tire pressure when the tire is used as a dual, that is, when four tires are put on each rear axle (a total of six or more tires on the vehicle).

Max. Load Single kg (lbs) at kPa (psi) Cold: This information indicates the maximum load and tire pressure when the tire is used as a single.

Load Range: This information identifies the tire's load-carrying capabilities and its inflation limits.

Tire Safety Tips

- Slow down if you have to go over a pothole or other object in the road.
- **DO NOT** run over curbs or other foreign objects in the roadway, and try not to strike the curb when parking.
- Check tire inflation pressure weekly during use to insure the maximum tire life and tread wear.
- **DO NOT** bleed air from tires when they are hot.
- Inspect tires for uneven wear patterns on the tread, cracks, foreign objects, or other signs of wear or trauma.
- Remove bits of glass and foreign objects wedged in the tread.
- Make sure your tire valves have valve caps.
- **ALWAYS** check tire pressure on tow vehicle and trailer before towing. Check tire pressure at least once a month.
- **DO NOT** overload tow vehicle. Check the tire information and loading placard for safe allowable tire loading conditions.

Tire Repair







The proper repair of a punctured tire requires a plug for the hole and a patch for the area inside the tire that surrounds the puncture hole. Punctures through the tread can be repaired if they are not too large, but punctures to the sidewall should not be repaired. Tires must be removed from the rim to be properly inspected before being plugged and patched.

Replacing Worn or Damaged Tires

Replace the tire before towing the trailer if the tire treads have less than 1/16 inch depth or the telltale bands are visible. Check inflation pressure weekly during use to insure the maximum tire life and tread wear. A bubble, cut or bulge in a side wall can result in a tire blowout. Inspect both side walls of each tire for any bubble, cut or bulge; and replace a damaged tire before towing the trailer.

TRAILER GUIDELINES

Table B below will help pinpoint the causes and solutions of tire wear problems.

Table B. Tire Wear Troubleshooting			
Wear Pattern		Cause	Solution
	Center Wear	Over inflation.	Adjust pressure to particular load per tire manufacturer.
	Edge Wear	Under inflation.	Adjust pressure to particular load per tire manufacturer.
	Side Wear	Loss of camber or overloading.	Make sure load does not exceed axle rating. Align wheels.
	Toe Wear	Incorrect toe-in.	Align wheels.
	Cupping	Out-of-balance.	Check bearing adjustment and balance tires.
	Flat Spots	Wheel lockup and tire skidding.	Avoid sudden stops when possible and adjust brakes.

WARNING



ALWAYS wear safety glasses when removing or installing force fitted parts. **DO NOT** attempt to repair or modify a wheel. **DO NOT** install an inner-tube to correct a leak through through the rim. If the rim is cracked, the air pressure in the inner tube may cause pieces of the rim to explode (break off) with great force and cause serious eye or bodily injury.

Wheel Rims

If the trailer has been struck, or impacted, on or near the wheels, or if the trailer has struck a curb, inspect the rims for damage (i.e. being out of round); and replace any damaged wheel. Inspect the wheels for damage every year, even if no obvious impact has occurred.

Wheels, Bearings and Lug Nuts

A loose, worn or damaged wheel bearing is the most common cause of brakes that grab.

To check wheel bearings, jack trailer and check wheels for side-to-side looseness. If the wheels are loose, or spin with a wobble, the bearings must be serviced or replaced. Check inflation pressure weekly during use to insure the maximum tire life and tread wear. Most trailer axles are built with sealed bearings that are not serviceable. Sealed bearings must be replaced as complete units.

NOTICE

NEVER use an pneumatic air gun to tighten wheel lug nuts.

Over-tightening lug nuts will result in breaking the studs or permanently deforming the mounting stud holes in the wheels.

WARNING

Lug nuts are prone to loosen after initial installation, which can lead to death or serious injury. Check all wheel lug nuts periodically.

Lug Nut Torque Requirements

It is extremely important to apply and maintain proper wheel mounting torque on the trailer. Be sure to use only the fasteners matched to the cone angle of the wheel. Proper procedure for attachment of the wheels is as follows:

1. Start all wheel lug nuts by hand.
2. Torque all lug nuts in sequence. See Figure L. **DO NOT** torque the wheel lug nuts all the way down. Tighten each lug nut in 3 separate passes as defined by Table C.
3. Check to see if the lug nuts are tight after the first 10, 25 and 50 miles of driving and before each tow thereafter

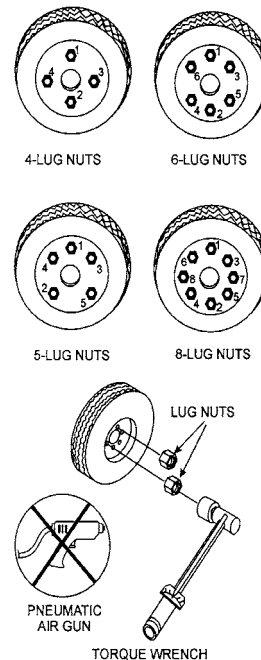

Figure L. Wheel Lug Nuts Tightening Sequence

TRAILER GUIDELINES

Table C. Tire Torque Requirements			
Wheel Size	First Pass FT-LBS	Second Pass FT-LBS	Third Pass FT-LBS
12"	20-25	35-40	50-65
13"	20-25	35-40	50-65
14"	20-25	50-60	90-120
15"	20-25	50-60	90-120
16"	20-25	50-60	90-120

Replace any broken or burned-out lamps as necessary. Check the wire harness for cuts, fraying or other damage. If it needs replacing, contact your dealer.

WARNING

Improper operating taillights, stoplights and turn signals can cause collisions.

Check all lights before each tow.

Lights and Signals

Before each tow, check the trailer taillights, stoplights, turn signals and any clearance lights for proper operation.

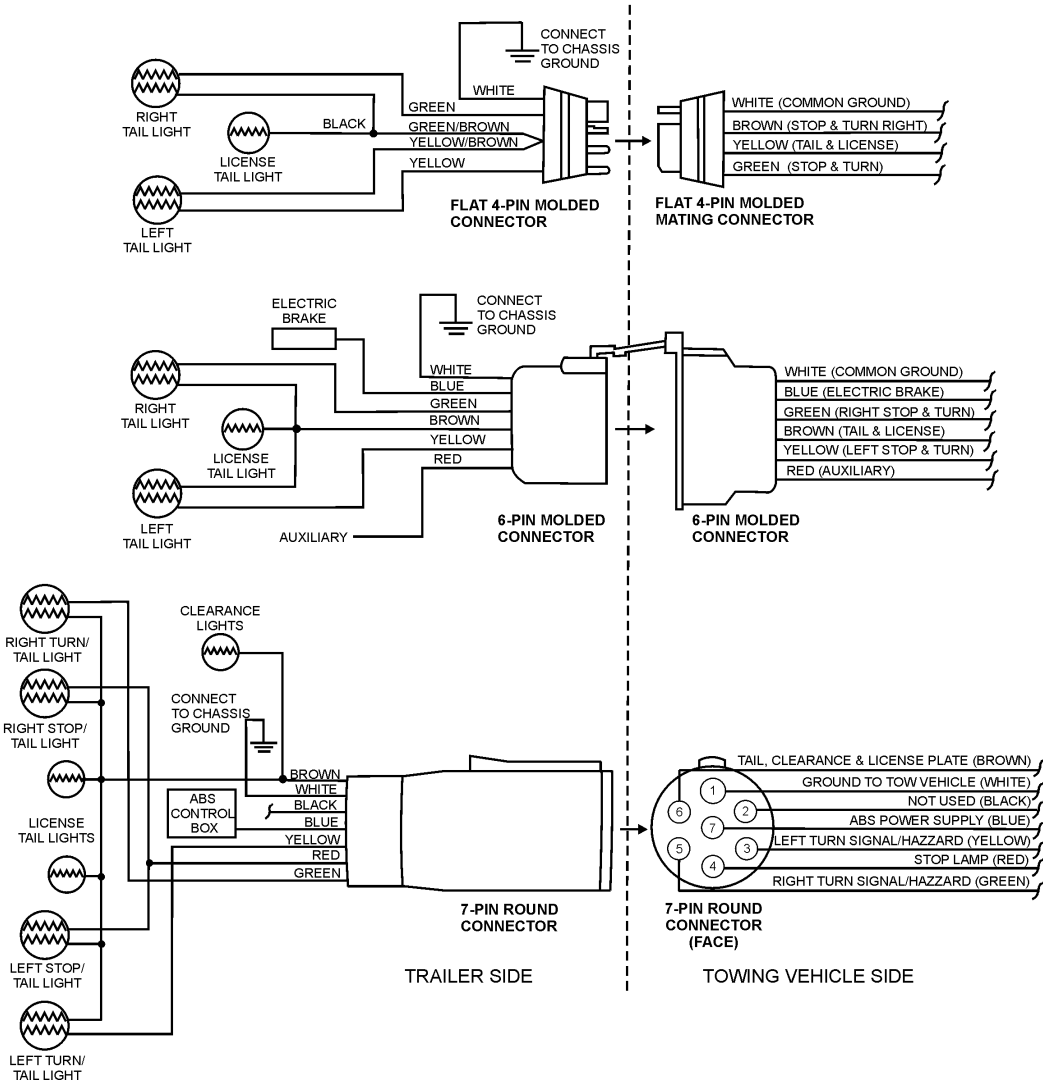

Figure M. Trailer to Tow Vehicle Wiring Diagram

APPENDIX — CONCRETE MIX INFORMATION

CONCRETE MIX INFORMATION

The following information has been extracted from actual testing laboratory reports. The purpose of this printing is only to help create a better understanding of the importance of uniform gradation and proportioning of materials which affect pumpability of concrete mixes. These weights and proportions illustrate that when the sieve analysis is ideal, the sand/rock ratio can be adjusted (65% sand 35% rock) and pumpability should be excellent.

EXAMPLE #1 (A California Test Lab. Report)

JOB:	Building Foundations (Water Project)
Sacks per cu./yd.	6.5 designed for 2,500 lbs. in 28 days
Gallons per sack	7.1
Washed Sand-#200 wash	1.3
Organic matter	OK
Specific gravity (SSD)	Sand-2.58; Pea Gravel-2.60

SIEVE ANALYSIS-PERCENT PASSING

Material	1.5" 1"	3/4"	3/8"	#4	#8	#16	#30	#50	#100	#200
W.C. Sand			100	99.7	79.1	60.4	36.5	14.3	4.0	1.1
Pea Gravel			100	3.0						
% Comb.			100	66	51	39	23	9	3	1.0

DESIGN FOR ONE YARD OF CONCRETE (SATURATED & SURFACE DRY):

Absolute volume of aggregate in one cu. yard:	17.78 cu. ft.
Specific gravity of aggregates in one cu. yard:	2.58
Weight of aggregates in one cu. yard batch:	2850 lbs.

	<u>%</u>	<u>BATCH</u>	<u>SPEC. GRAVITY</u>	<u>ABS. VOL.</u>
W.C. Sand	65	1800	2.58	11.56
PEA GRAVEL	35	1000	2.60	6.22
WATER 46 gal.		1		
CEMENT 6.5 sk.		611		
TOTAL				27.00

ADMIXTURE: None













SLUMP 4"

REMARKS This mix is designed for pumping

NOTE: Due to the availability of well-graded sand as shown in the above sieve analysis, this mix pumped very successfully.

APPENDIX — CONCRETE MIX INFORMATION

A.S.T.M. STANDARD SPECIFICATION FOR GRADING AGGREGATE

SCREEN TYPE	U.S.	METRIC	PERCENTAGE PASSING BY WEIGHT
FINE AGGREGATE: Referred to as washed concrete sand.			
3/8" 	3/8"	9.50 mm	100%
#4 	4,760 microns	4.76 mm	95 to 100%
#8 	2,380 microns	2.38 mm	80 to 100%
#16 	1,190 microns	1.19 mm	50 to 85%
#30 	590 microns	.59 mm	50 to 85 %
#50 	297 microns	297µm	10 to 30%
#100 	149 microns	149µm	2 to 10%
3/8 (9.51 mm) PEA GRAVEL AGGREGATE: Referred to as #4 Rock or Gravel or 1/2" minus (12.7 mm) size			
1/2" 	1/2"	12.70 mm	100%
3/8" 	3/8"	9.51 mm	85 to 100%
#4 	4,760 microns	4.76 mm	10 to 30%
#8 	2,380 micron	2.38 mm	0 to 10%
#16 	1,190 microns	1.19 mm	0 to 5%

APPENDIX — CONCRETE MIX INFORMATION

SLUMP TEST PROCEDURE

1. To obtain a representative sample (concrete), take several samples at three or more regular intervals throughout the discharge of the mixer or truck. **DO NOT** take samples at the beginning or end of the discharge.
2. Dampen the inside of the cone and place it on a smooth, moist, non-absorbent, level surface large enough to accommodate both the slumped concrete and the slump cone. Stand on the “foot pieces” throughout the test procedure to hold the cone firmly in place.
3. Fill the cone 1/3 full by volume (Figure N) and rod 25 times with a 1/2” dia x 24” lg. bullet-pointed steel rod. (This is a specific requirement which will produce non-standard results unless followed exactly.) Distribute rodding evenly over the entire cross section of the sample.

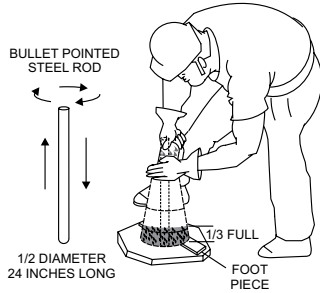

Figure N. Slump Test (1/3 Full)

4. Fill cone another 1/3 (Figure O) which will make the cone 2/3 full by volume. Rod this second layer 25 times with the rod penetrating into, but not through, the first layer. Distribute rodding evenly over the entire cross section of the layer.

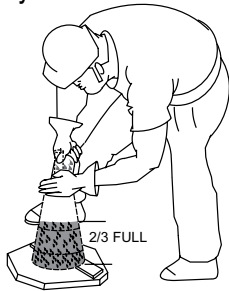

Figure O. Slump Test (2/3 Full)

5. Fill cone to overflowing (Figure P). Rod this layer 25 times with rod penetrating into, but not through, the second layer. Distribute rodding evenly over the entire cross section of this layer.

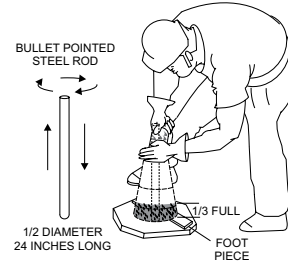

Figure P. Slump Test (Full-Overflow)

6. Remove the excess concrete (Figure Q) from the top of the cone, using the tamping rod as a screed.



Figure Q. Slump Test (Removing Excess Concrete)

7. Lift the cone vertically (Figure R) with a slow even motion. **DO NOT** jar the concrete or tilt the cone during this process. Invert the withdrawn cone, and place it next to, but not touching the slumped concrete.

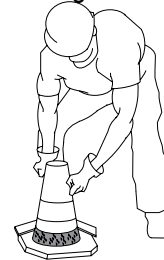

Figure R. Slump Test (Cone Invert)

8. Lay a straight edge (Figure S) across the top of the slumped cone. Measure the amount of slump in inches from the bottom of the straight edge to the top of the slumped concrete at a point over the original center of the base. The slump operation must be complete in a maximum elapsed time of 1-1/2 minutes. Discard the concrete. **DO NOT** use it in another test.



Figure S. Slump Test (Measurement)

TROUBLESHOOTING (PUMP)

Troubleshooting (Pump)		
Symptom	Possible Problem	Solution
Main Hydraulic Cylinder will not cycle	Incorrect System Operating Pressure	Check the pump pressure gage. Verify it is approx. 4400 PSI
	Incorrect Engine RPM setting	Verify the engine's high RPM speed is set to 2550
	Contaminated Main Relief Valve	Check the manifold for a contaminated Relief Valve
	Obstructed Material Cylinders	check for obstructions (dried material) inside the cylinders
Hopper Remix Paddles will not rotate	Incorrect Directional Control Operating Pressure	Verify the Directional Control operating pressure is approx. 1000 PSI
	Contaminated Relief Valve	Check the manifold for a contaminated Relief Valve
	Broken Shaft Coupler Key	Check the Hopper Remixer shaft coupler for a broken key
	Loose Shaft Retaining Set Collar	Check the Shaft Retaining Set Collar for tightness
Shuttle Cylinder does not stroke	Incorrect Accumulator System Pressure	Check the system pressure reading. Verify it is approx. 1750 PSI
	Contaminated Relief Valve	Check the manifold for a contaminated Relief Valve
	Swing Solenoid not energizing	Check for burned out solenoid and 12V signal voltage
	Swing Valve not functioning properly	Manually cycle the pump using the manual cylinder jogging switch
Shuttle Cylinder slow to complete stroke	Improper Flow Control setting	Fully open Flow Control Valve
	Incorrect Engine RPM setting	Verify the engine's high RPM speed is set to 2550
	Incorrect Main Hydraulic System Operating Pressure	Check the pump pressure gage. Verify it is approx. 3200 PSI
	Contaminated Swing Relief Cartridge	Check the manifold for contaminated Swing Relief Cartridge
	Low Accumulator System Pressure	Check the accumulator pressure reading. Verify it is approx. 1750 PSI
	Hopper Discharge Nipple Seal improperly lubricated	Check the Hopper Discharge Nipple Seal for siezing and lack of lubricant
Concrete slurry in lubrication box	Worn or defective urethane cups or worn material cylinder	Replace
Material cylinder piston cups squeel	Low on lubrication	Check oil level

TROUBLESHOOTING (PUMP)

Troubleshooting (Pump — Continued)		
Symptom	Possible Problem	Solution
Pump Engine will idle but not increase to full operating speed	Throttle Control Block Solenoid not energizing	Check for burned out solenoid and computer ground activation voltage.
Battery voltage falls below 12VDC on digital display, causing engine not to start	Blown out Fuse	Check the fuse
	Dead battery	Check the charge on the battery
	Wiring connection inside Control Box	Check the wiring connections and verify power is reaching ignition switch
Main Hydraulic Pump Noisy	Insufficient oil	Check oil level and for closed suction strainer
	Air in system	Check for aeration reservoir
		Vacuum leak in suction line
	Excessive pump wear	Repair or replace
Excessive engine speed	Check for correct engine RPM	
Engine bogs down	Low engine speed	Check engine RPM
	Main relief cartridge set to low	Adjust relief cartridge
	Engine overloaded when pumping	Decrease volume control on main pump
Material hose pack		
Machine does not deliver volume and pressure	Low engine speed	Check engine RPM
	Volume control set to low	Adjust control to full open setting
	Main hydraulic pressure too low	Check for proper pressure or for contaminated relief cartridge
Hydraulic fluid gets hot	Cooling fan	Check fan electrical connection or for burnt fan motor.
		Fan rotating in wrong direction
	Contaminated cooler fins	Clean cooler fins
	Return filter element closed	Replace filter
	Main relief cartridge contaminated or set too low	Replace or set to proper pressure
Accumulator gauge reads below 1750 PSI	Hydraulic oil level too low	Fill to proper level
	Accumulator bottle low on nitrogen	Check precharge pressure 1100 PSI
	Contaminated safety relief cartridge	Replace cartridge
	Defective unloader cartridge electrical coil	Replace
	Unloader cartridge coil not energizing	Check for 12 Volt signal voltage
Cylinders not completely extended (short stroke)	Defective gear pump	Replace pump
	Excessive amount of hydraulic on cylinder rod side	Inspect cylinder. Check values for contamination or faulty spring
	Hydraulic cylinder piston head seal leaking	Replace seals

TROUBLESHOOTING (ENGINE)

Troubleshooting (Diesel Engine)		
Symptom	Possible Problem	Solution
Engine will not start or start is delayed, although engine can be turned over.	No Fuel reaching injection pump?	Add fuel. Check entire fuel system.
	Defective fuel pump?	Replace fuel pump.
	Fuel filter clogged?	Replace fuel filter and clean tank.
	Faulty fuel supply line?	Replace or repair fuel line.
	Compression too low?	Check piston, cylinder and valves. Adjust or repair per engine repair manual.
	Fuel pump not working correctly?	Repair or replace fuel pump.
	Oil pressure too low?	Check engine oil pressure.
	Low starting temperature limit exceeded?	Comply with cold starting instructions and proper oil viscosity.
	Defective battery?	Charge or replace battery.
	Air or water mixed in fuel system?	Check carefully for loosened fuel line coupling, loose cap nut, etc.
At low temperatures engine will not start.	Engine oil too thick?	Refill engine crankcase with correct type of oil for winter environment.
	Defective battery?	Replace battery.
Engine fires but stops soon as starter is switched off.	Fuel filter blocked?	Replace fuel filter.
	Fuel supply blocked?	Check the entire fuel system.
	Defective fuel pump?	Replace fuel pump.
Engine stops by itself during normal operation.	Fuel tank empty?	Add fuel.
	Fuel filter blocked?	Replace fuel filter.
	Defective fuel pump?	Replace fuel pump.
	Mechanical oil pressure shutdown sensor stops the engine due to low oil?	Add oil. Replace low oil shutdown sensor if necessary.
Low engine power, output and speed.	Fuel tank empty?	Replace fuel filter.
	Fuel filter clogged?	Replace fuel filter.
	Fuel tank venting is inadequate?	Ensure that tank is adequately vented.
	Leaks at pipe unions?	Check threaded pipe unions tape and tighten unions as required.
	Speed control lever does not remain in selected position?	See engine manual for corrective action.
	Engine oil level too full?	Correct engine oil level.
	Injection pump wear?	Use No. 2-D diesel fuel only. Check the fuel injection pump element and delivery valve assembly and replace as necessary.

TROUBLESHOOTING (HYDRAULIC BRAKES)

Troubleshooting (Hydraulic Brakes)		
Symptom	Possible Problem	Solution
No brakes	Is the brake line broken or kinked?	Repair or replace.
Weak brakes or brakes pull to one side	Is the brake lining glazed?	Reburnish or replace
	Is the trailer overloaded?	Correct weight.
	Are the brake drums scored or grooved?	Check machine or replace.
	Is the tire pressure correct?	Inflate all tires equally per manufacturer guidelines.
	Are the tires unmatched on the same axle?	Match tires.
Locking brakes	Are the brake components loose, bent or broken?	Replace components.
	Are the brake drums out-of-round?	Replace.
Noisy brakes	Is the brake system lubricated?	Lubricate.
	Are the correct brake components installed?	Replace and correct.
Dragging brakes	Is the brake lining thickness correct or installed incorrectly?	Install new shoes and linings.
	Is there enough brake fluid or correct fluid?	Fill with DOT 4 fluid.
Brakes squeak, chatter or chuck	Overheated wheel bearing	Replace wheel bearing and pack with grease.
	Low brake fluid	Fill and bleed brake system.
	Siezed acuator master cylinder	Replace/Rebuild master cylinder.
	Brake shoe noise	Inspect drums. Adjust shoes or replace if necessary.
Brakes overheat, fail to operate, pull to the side, or function poorly	Leaking wheel cylinder	Check and replace wheel cylinder and bleed brake system.
	Low brake fluid level	Fill with dot approved brake fluid and bleed brake system.
	Brake actuator frame damage	Replace complete actuator unit.
	Brake line being pinched	Replace brake line.
	Seized actuator	Replace or rebuild actuator.
	Broken return spring	Replace spring.
	Brakes improperly adjusted	Check adjustment.
Break-away cable system partially activated	Break-away cable might be pulled. Determine cause and correct. Pry up on cable until indicator bead touches or rests against cable spring stop. This will fully release the frame brakes and prevent drag.	

TROUBLESHOOTING (ELECTRICAL)

Troubleshooting (Electrical)		
Malfunction Reading (Screen 1)	Possible Problem	Solution
Main A OPEN	Burnt 12 V cycling solenoid.	Measure solenoid coil resistance. It should read 6 ohms. Replace burnt solenoid.
	Wire connection broken.	Replace broken wire.
Main A SHORTED	The 12-volt cycling solenoid is shorted directly to ground.	Measure solenoid coil resistance. It should read 6 ohms. Replace shorted solenoid.
	Wire connection is shorted directly to the ground.	Correct connection.
Main B OPEN	Burnt 12 V cycling solenoid.	Measure solenoid coil resistance. It should read 6 ohms. Replace burnt solenoid.
	Wire connection broken.	Replace broken wire.
Main B SHORTED	The 12-volt cycling solenoid is shorted directly to ground.	Measure solenoid coil resistance. It should read 6 ohms. Replace shorted solenoid.
	Wire connection is shorted directly to the ground.	Correct connection.
Swing OPEN	Burnt 12 V cycling solenoid.	Measure solenoid coil resistance. It should read 6 ohms. Replace burnt solenoid.
	Wire connection broken.	Replace broken wire.
Swing SHORTED	The 12-volt cycling solenoid is shorted directly to ground.	Measure solenoid coil resistance. It should read 6 ohms. Replace shorted solenoid.
	Wire connection is shorted directly to the ground.	Correct connection.
Throttle solenoid open	Burnt 12 V cycling solenoid.	Measure solenoid coil resistance. It should read 6 ohms. Replace burnt solenoid.
	Wire connection broken.	Replace broken wire.
Throttle solenoid shorted	The 12-volt cycling solenoid is shorted directly to ground.	Measure solenoid coil resistance. It should read 6 ohms. Replace shorted solenoid.
	Wire connection is shorted directly to the ground.	Correct connection.
Fuel solenoid open	Burnt 12 V cycling solenoid.	Measure solenoid coil resistance. It should read 6 ohms. Replace burnt solenoid.
	Wire connection broken.	Replace broken wire.
Fuel solenoid shorted	The 12-volt cycling solenoid is shorted directly to ground.	Measure solenoid coil resistance. It should read 6 ohms. Replace shorted solenoid.
	Wire connection is shorted directly to the ground.	Correct connection.

CONTROL BOX COMPONENT LOCATOR

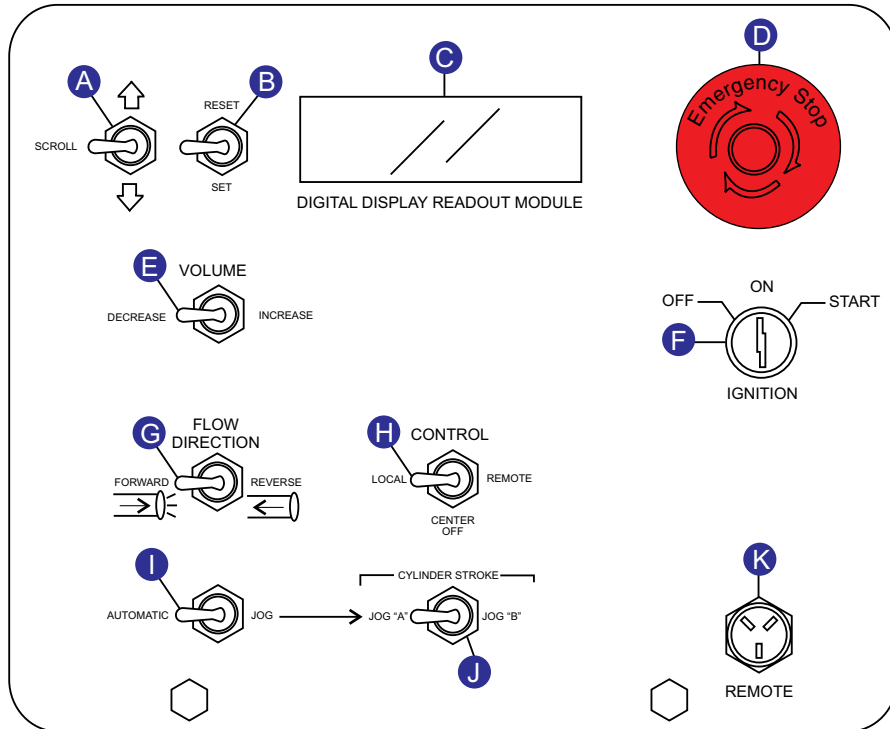

WIRING DIAGRAM CONTROL BOX (INTERNAL)

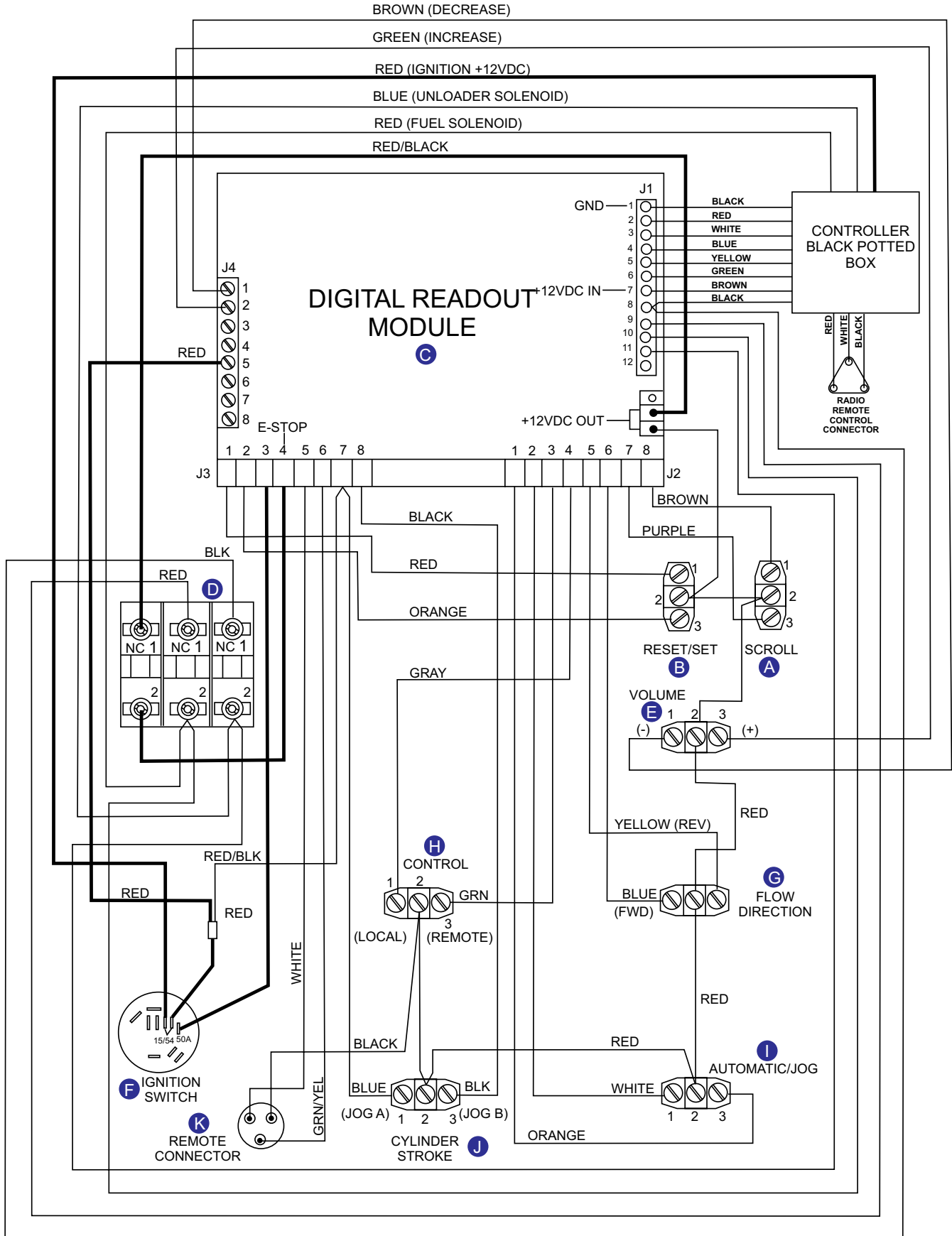

HOPPER VIBRATOR LOCATOR (OPTION)

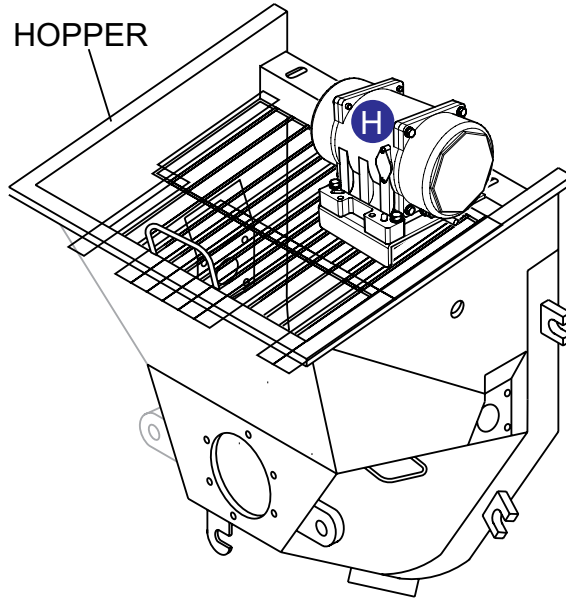
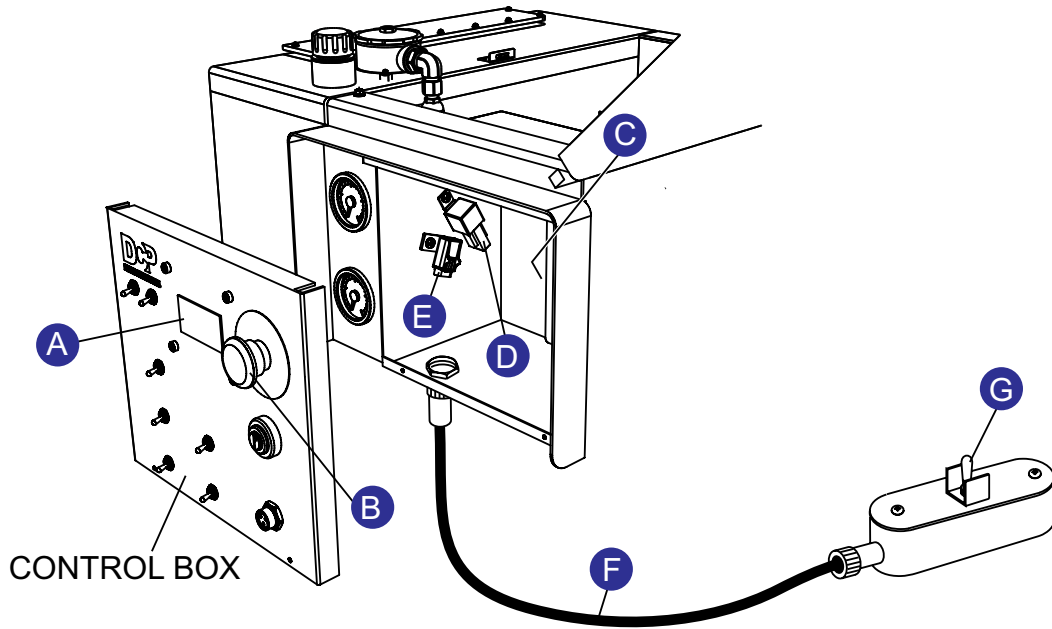

WIRING DIAGRAM HOPPER VIBRATOR (OPTION)

CONTROL BOX INTERIOR VIBRATOR RELAY

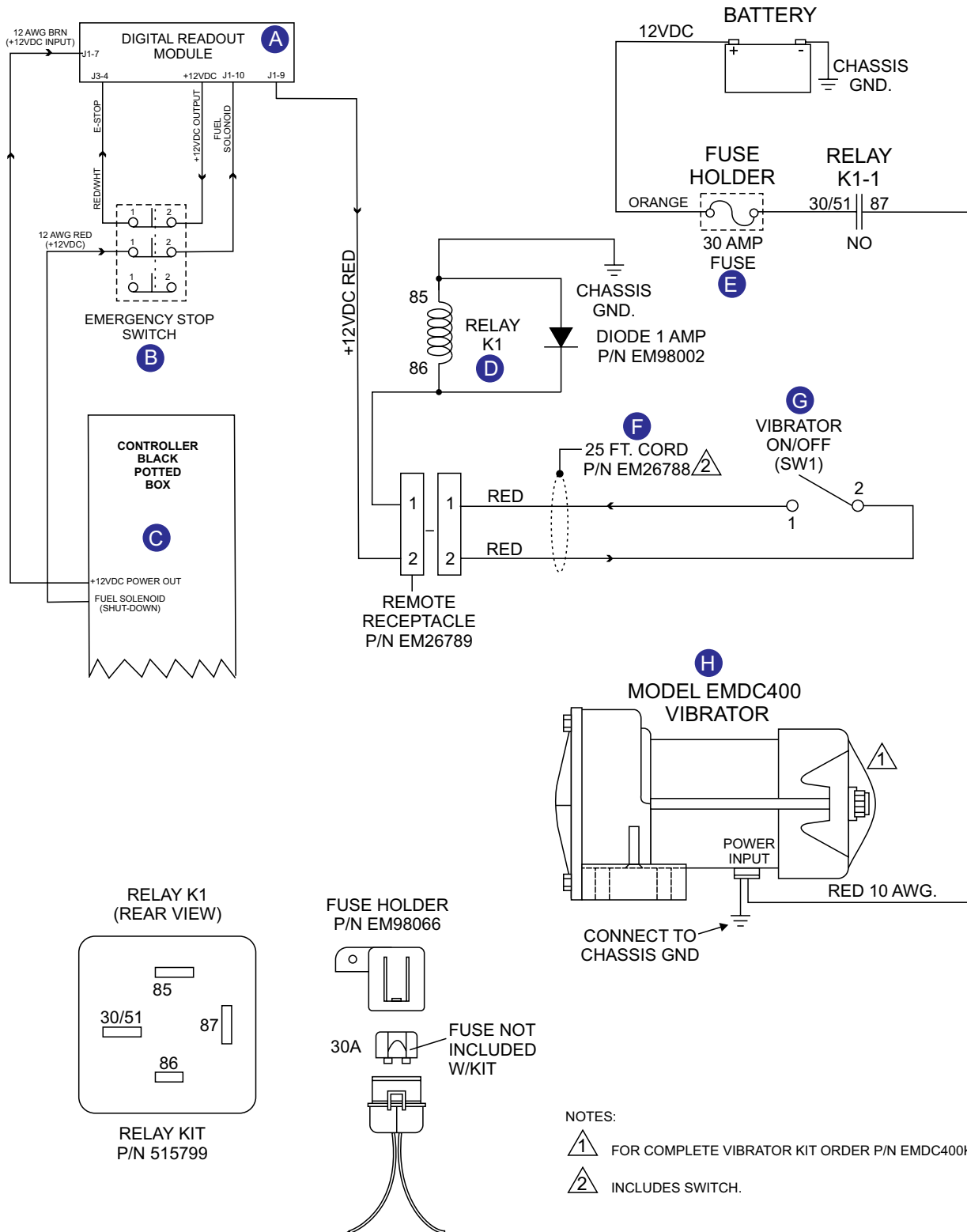

HYDRAULIC SYSTEM LOCATOR DIAGRAM

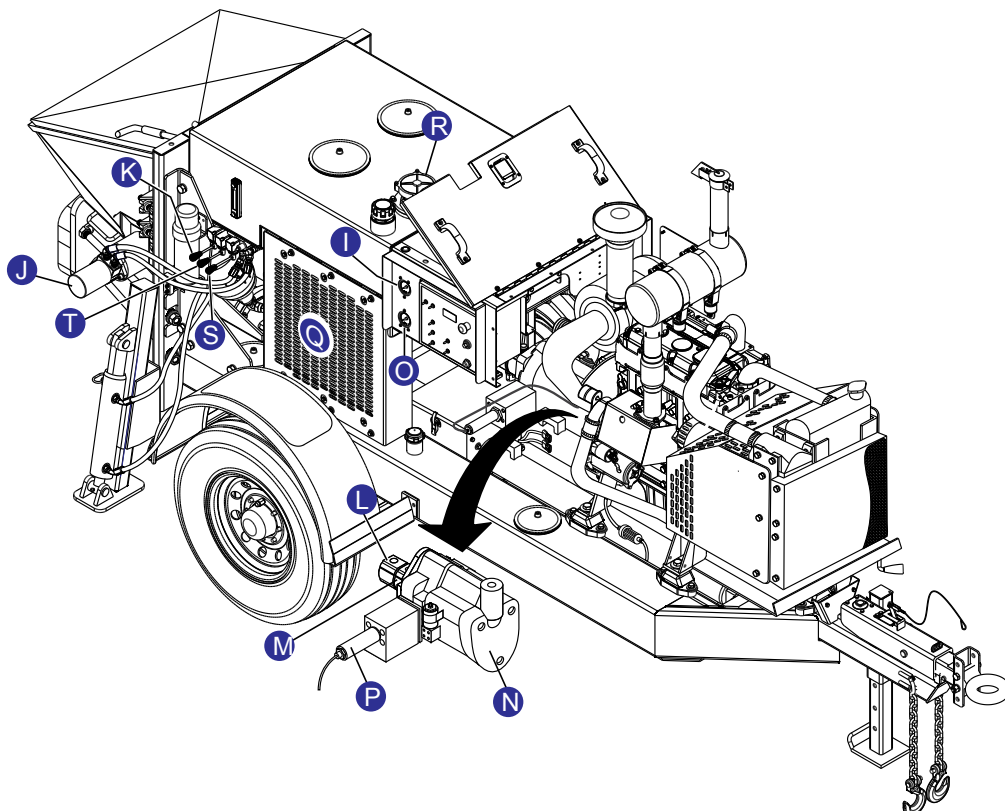
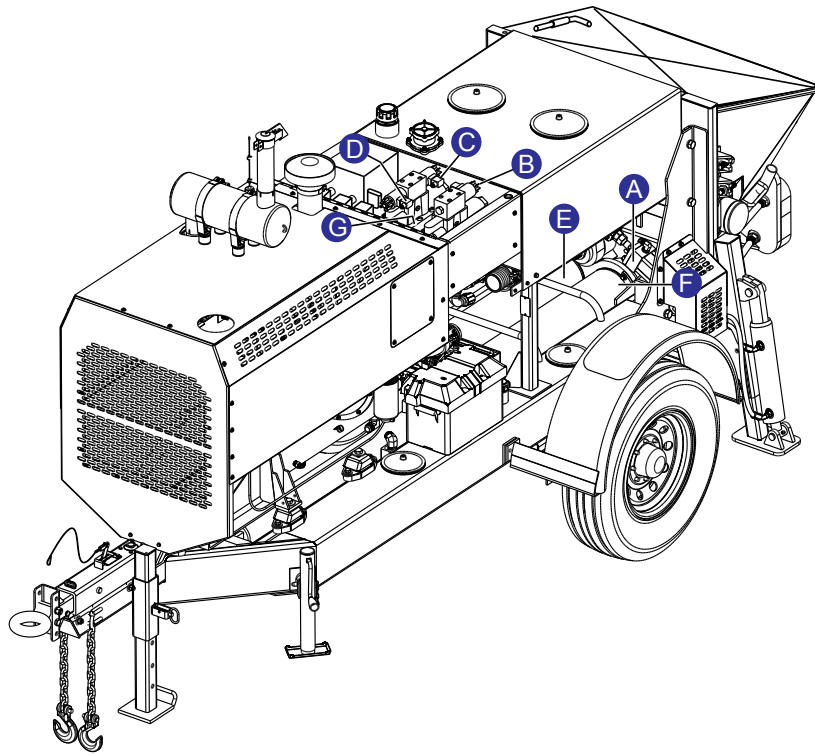

HYDRAULIC SYSTEM DIAGRAM

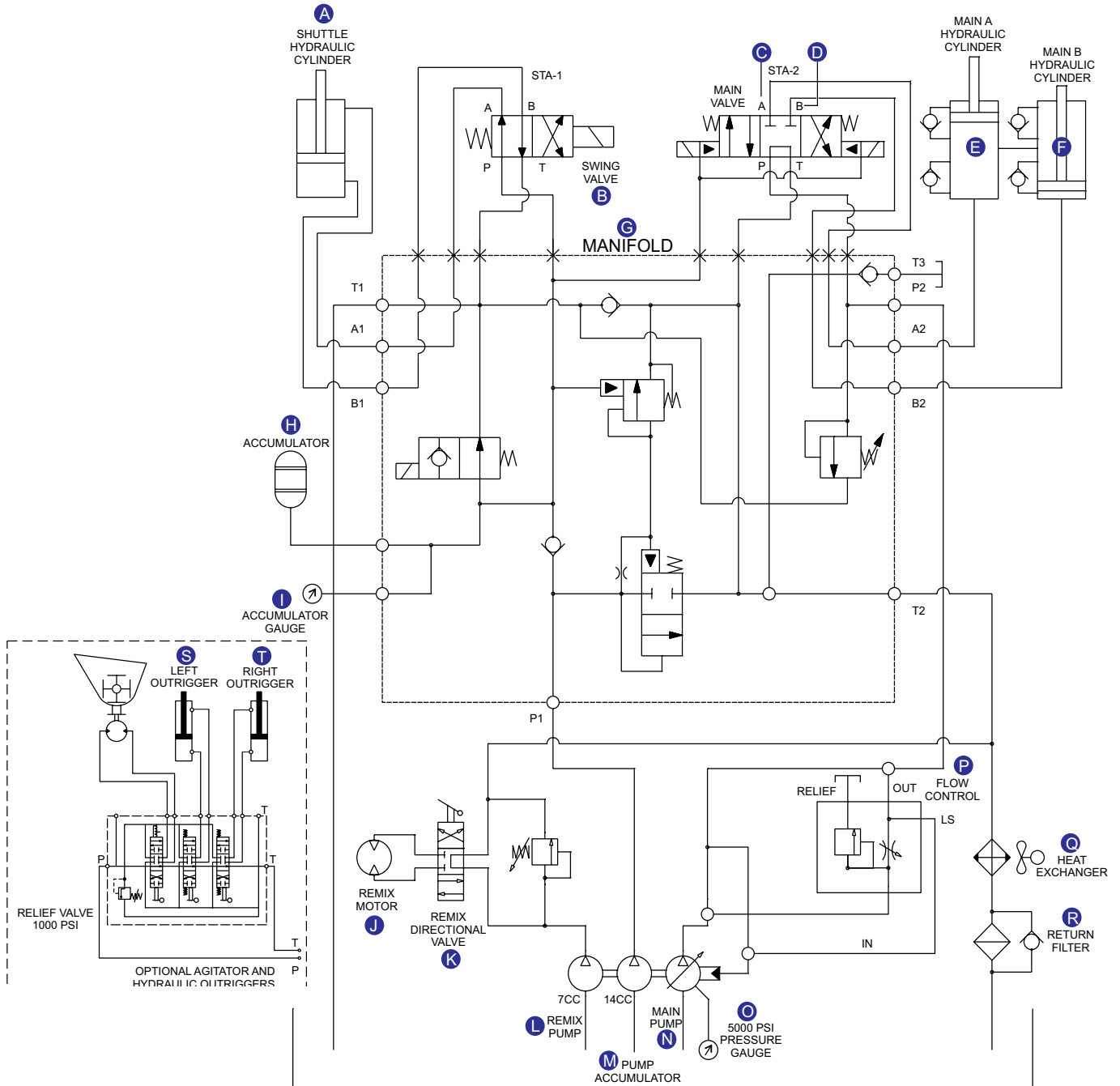

WIRING DIAGRAM LOCATOR 1 (EXTERNAL CONTROL BOX)

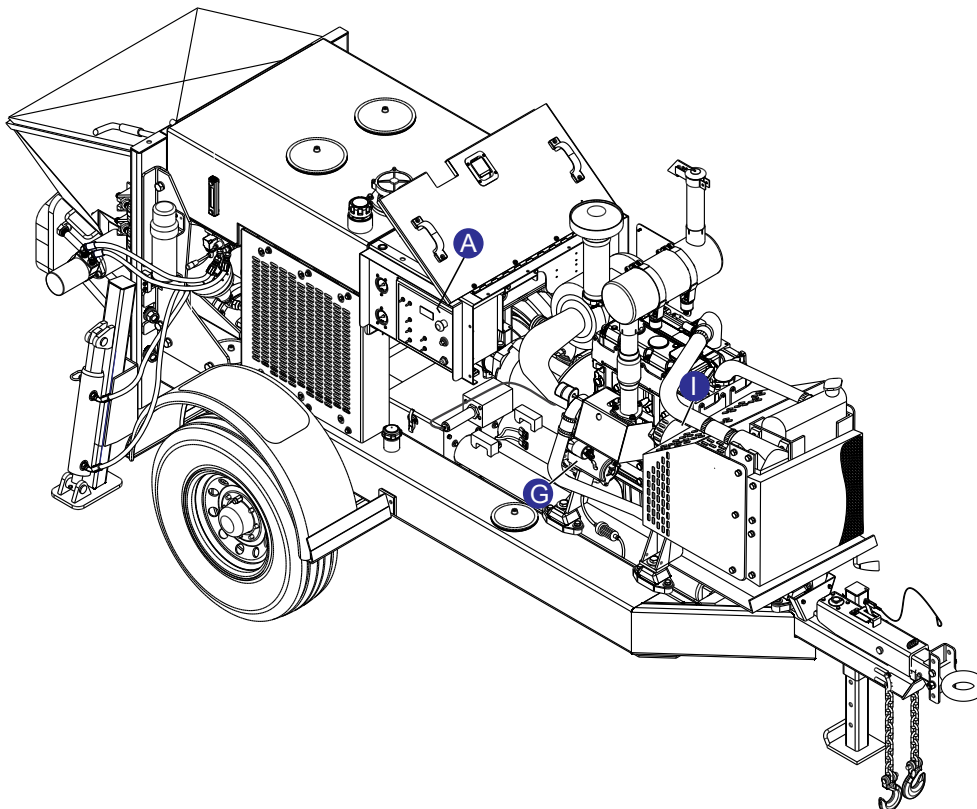
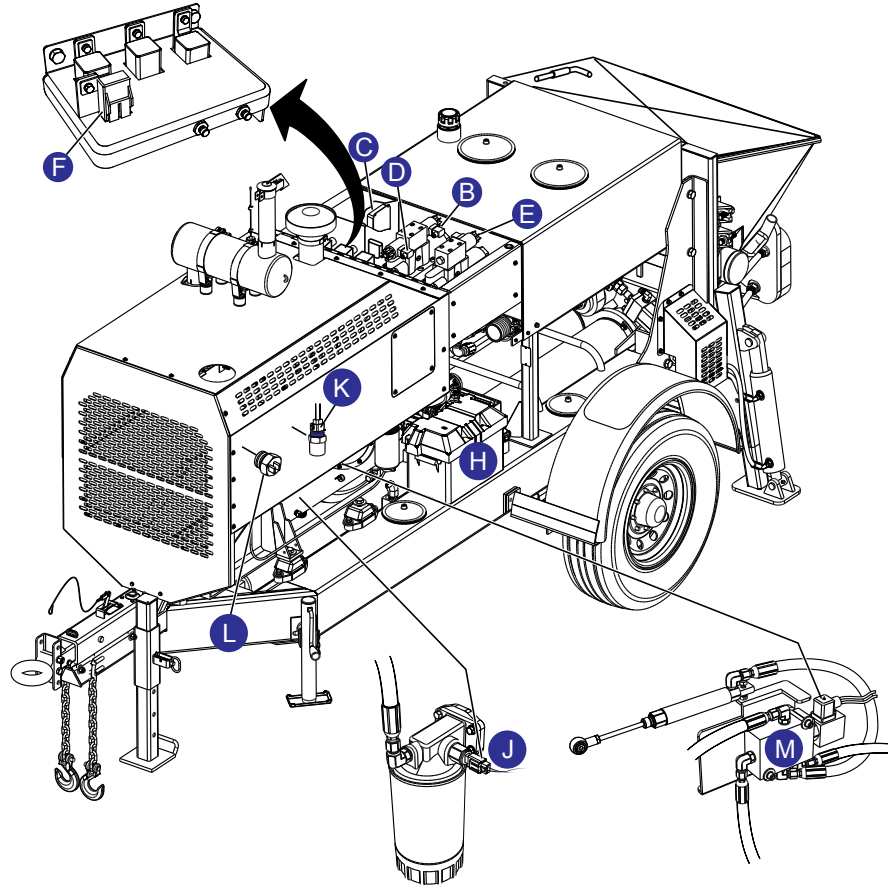

WIRING DIAGRAM 1 (EXTERNAL CONTROL BOX)

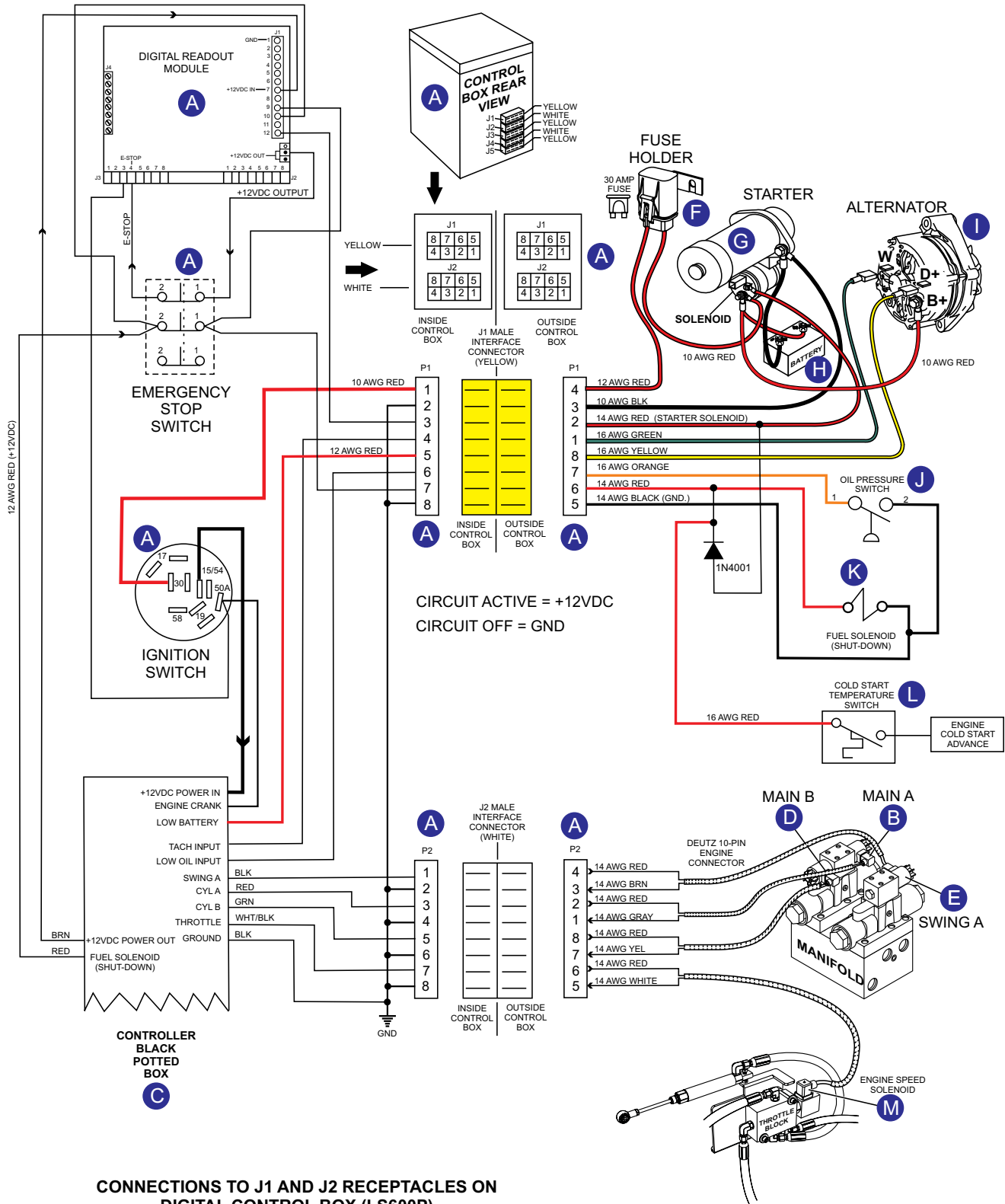

WIRING DIAGRAM LOCATOR 2 (EXTERNAL CONTROL BOX)

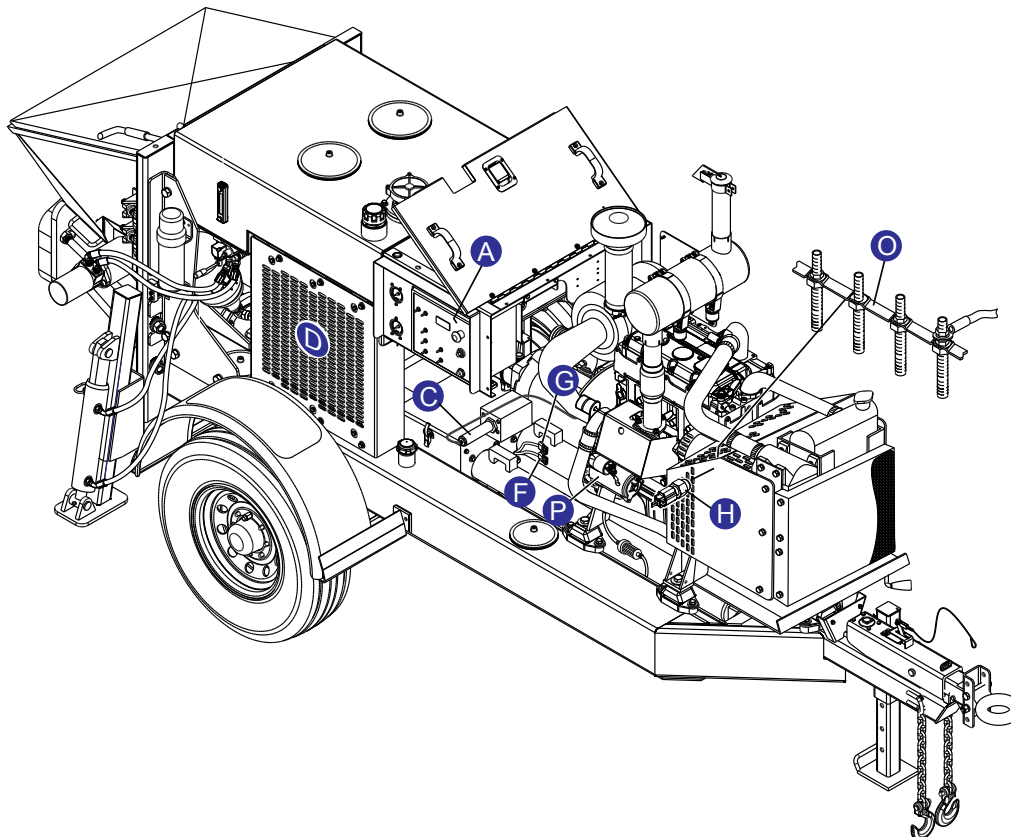
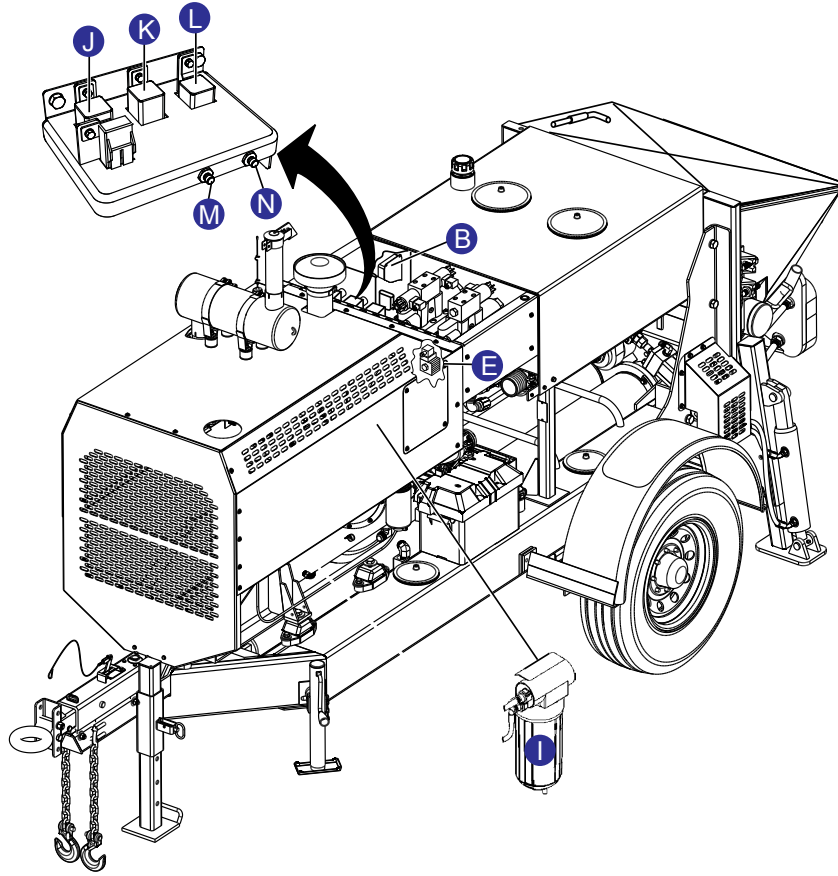

WIRING DIAGRAM 2 (EXTERNAL CONTROL BOX)

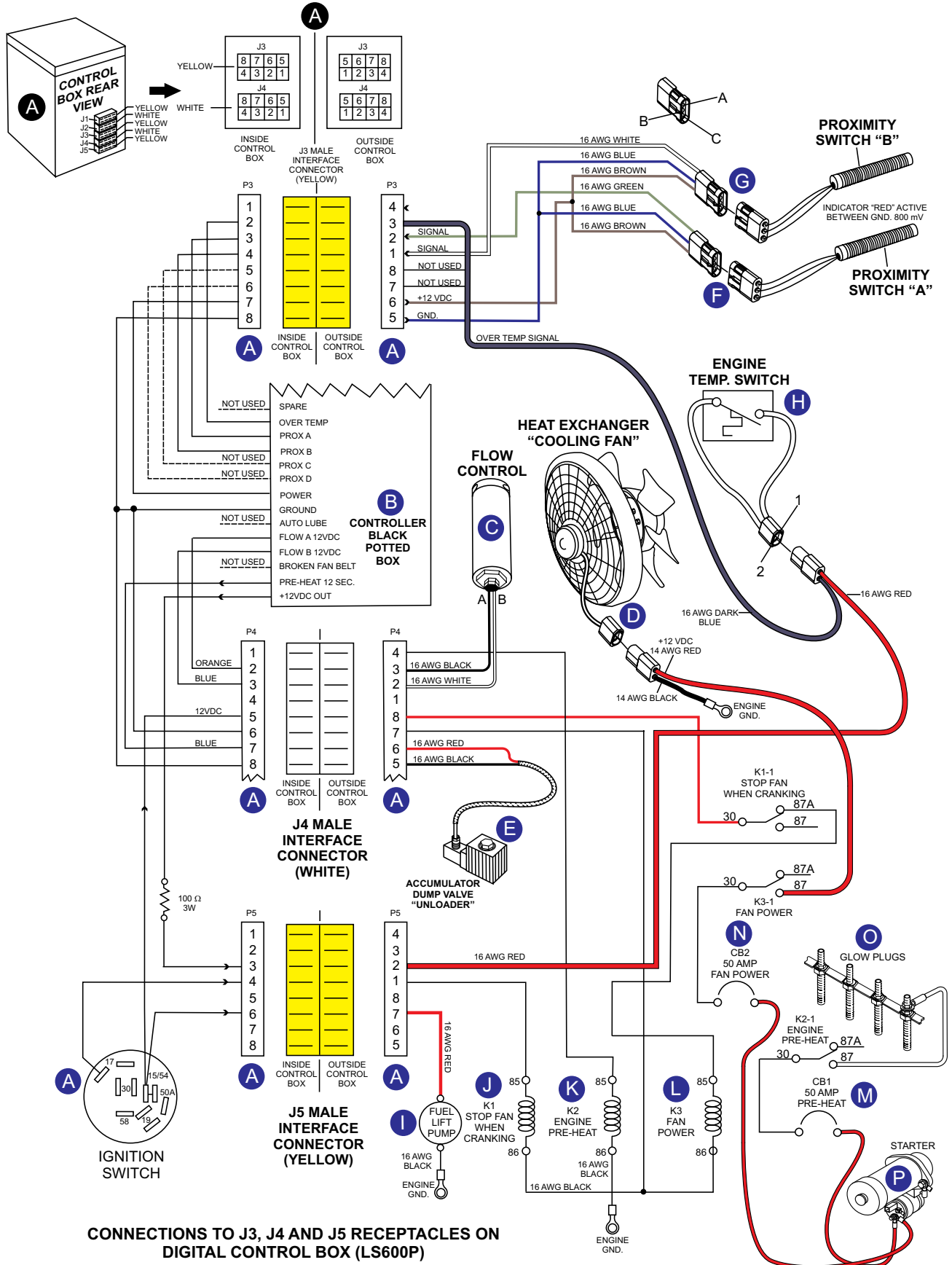

OPERATION MANUAL

HERE'S HOW TO GET HELP

PLEASE HAVE THE MODEL AND SERIAL
NUMBER ON-HAND WHEN CALLING

UNITED STATES

Multiquip Corporate Office

18910 Wilmington Ave.
Carson, CA 90746
Contact: mq@multiquip.com

Tel. (800) 421-1244
Fax (310) 537-3927

Service Department

800-421-1244
310-537-3700

Fax: 310-537-4259

Technical Assistance

800-478-1244

Fax: 310-943-2238

MQ Parts Department

800-427-1244
310-537-3700

Fax: 800-672-7877
Fax: 310-637-3284

Warranty Department

800-421-1244
310-537-3700

Fax: 310-943-2249

MEXICO

MQ Cipsa

Carr. Fed. Mexico-Puebla KM 126.5
Momoxpan, Cholula, Puebla 72760 Mexico
Contact: pmastretta@cipsa.com.mx

Tel: (52) 222-225-9900
Fax: (52) 222-285-0420

CANADA

Multiquip

4110 Industriel Boul.
Laval, Quebec, Canada H7L 6V3
Contact: jmartin@multiquip.com

Tel: (450) 625-2244
Tel: (877) 963-4411
Fax: (450) 625-8664

UNITED KINGDOM

Multiquip (UK) Limited Head Office

Unit 2, Northpoint Industrial Estate,
Globe Lane,
Dukinfield, Cheshire SK16 4UJ
Contact: sales@multiquip.co.uk

Tel: 0161 339 2223
Fax: 0161 339 3226

© COPYRIGHT 2013, MULTIQUIP INC.

Multiquip Inc, the MQ logo and the Mayco logo are registered trademarks of Multiquip Inc. and may not be used, reproduced, or altered without written permission. All other trademarks are the property of their respective owners and used with permission.

This manual MUST accompany the equipment at all times. This manual is considered a permanent part of the equipment and should remain with the unit if resold.

The information and specifications included in this publication were in effect at the time of approval for printing. Illustrations, descriptions, references and technical data contained in this manual are for guidance only and may not be considered as binding. Multiquip Inc. reserves the right to discontinue or change specifications, design or the information published in this publication at any time without notice and without incurring any obligations.

Your Local Dealer is:

